

RIS H

RIS P

UFR



F6 + **F8**



HEAT RECOVERY AND FILTRATION UNITS



Regulation on heating installations in buildings



OUR COMMITMENT TO THE ENVIRONMENT

Sodeca has begun a new stage of study and design of new trends in ventilation which will help to preserve the environment and to make the energy saving which so much concerns today's society.



To obtain an **improvement in energy efficiency** of fans and of ventilation facilities, the engineering department of Sodeca has **balanced the energy consumption of the fans** with their maximum performance, in the habitual areas of work. This has required a restructuring of the curves and their presentation in this and future Sodeca catalogues.

SODECA has concentrated its activity on the production of industrial fans, ventilation systems and extractors for the removal of smoke in case of fire since 1983, when it was founded.

SODECA's fans and extractors are present in all European countries and in many parts of the world, thanks to the quality of the product and the methods of research and development used.

Our quality procedures used and certified by BUREAU VERITAS, in accordance with ISO 9001:2008, are another of the reasons which make **SODECA** one of the best and most renowned fan manufacturers in Europe.

Without a doubt, the most important factor to achieve our objectives is the human factor, the great professionals who work at your service, offering not only ventilation equipment but also solutions to any ventilation need required by our customers.

We sincerely offer you the possibility of visiting our facilities in Sant Quirze de Besora, with over 16,000 square metres of built area, where you will be able to see our fan manufacture with perfect clarity and with the highest standards of quality, complying with the ISO and AMCA standards.

This catalogue is only a small part of our possibilities. Do not hesitate to contact us. We will put all our experience and our human resources at your disposal.



*installations
headquarters of
SODECA s.a.,
at Sant Quirze
de Besora and
manufacturing plant
in Santiago
de Chile.*

HEAT RECOVERY FILTRATION UNITS

Sodeca has begun a new stage of study and design of new products and trends related with ventilation, which will help to preserve the environment and to make the energy saving which so much concerns today's society.



Our aims are:

- Energy saving and in consequence savings of natural resources and also economic savings
- Improvement in energy efficiency
- Reduction of acoustic contamination
- Protection of the environment

In order to fulfil our objectives, **SODECA** is presenting its new products in this catalogue so as to fulfil the demands and guidelines of **R.I.T.E.** (Regulations of Heat Installations in Buildings), and to achieve with these series a real energy saving in air-conditioning installations:

- HEAT RECOVERY UNITS
- FILTRATION UNITS



Examples of installations according to RITE:

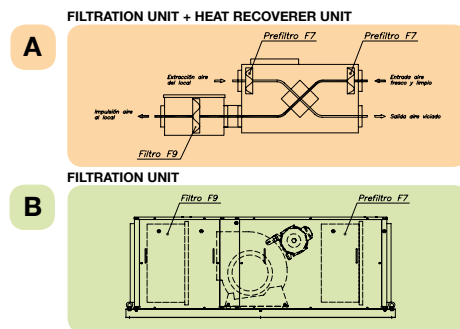

Translation of literals from the graph
 Filtro F9: F9 Filter
 Prefiltro F7: F7 Pre-filter
 Extracción aire del local: Extraction of air from the premises
 Entrada aire fresco y limpio: Entry of fresh, clean air
 Impulsión aire al local: Impulsion of aire from the premises
 Salida aire viciado: Outlet of used air

A: Solutions with recuperators or combinations of recuperators and filtration units
B: Solutions with filtration units

HEAT RECOVERY UNITS COMFORT AND ENERGY SAVING



With energy, heat or cold recuperators it will no longer be a problem to combine the ventilation with the air-conditioning or heating systems. Apart from recovering and conserving energy, the recuperators, with their entry filters and air outlet, will make the environment clean and comfortable.

OPERATION

The heat recuperator operates by means of the combination of two centrifugal fans with a low sound level, where one of them carries out the extraction of the used air from the interior of the premises to the street, and the other drives fresh air from outside into the interior of the premises. The two circuits cross without mixing, in a plate exchanger, where the heat from the outgoing air is transferred to the fresh air from the exterior, heating it up.

In this way, we manage to recover a high percentage of the energy used to heat up or cool down the air in the interior of the premises and re-use it. Without the use of the recuperator, this energy would be totally lost.

Operating diagram:

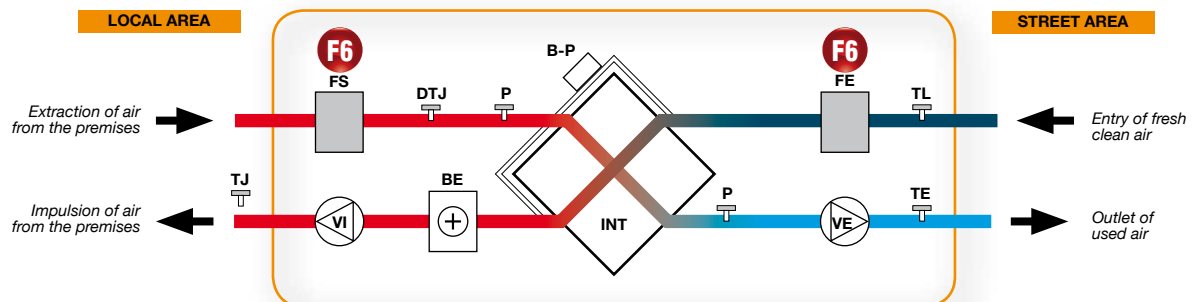

- VE:** Air extractor
- VI:** Impulsion fan
- INT:** Exchanger
- BE:** Electrical battery
- FE:** Entry filter F-6
- FS:** Entry filter F-6
- TJ:** Temperature sensor for driven air
- TL:** Temperature sensor for incoming air
- TE:** Temperature sensor for outgoing air
- DTJ:** Humidity and temperature sensor
- P:** Pressure inlet
- BP:** By-Pass Hatch

FILTRATION UNITS

SODECA is presenting the new series of filtration units so as to fulfil the guidelines of R.I.T.E. (Regulations of Heat Installations in Buildings), to fulfil the demands of energy efficiency and air quality in the interior of buildings.

INTERIOR AIR QUALITY

The buildings will have a ventilation system to bring in an external air flow which avoids, in the different premises, the formation of high concentrations of contaminants. The external air will be brought in properly filtered.



IDA 1

Top-quality air

Application: hospitals, clinics, laboratories and nurseries



IDA 2

Good-quality air

Application: offices, old people's homes, communal areas in hotels, classrooms, swimming pools, museums and premises of similar characteristics



IDA 3

Average quality air

Application: commercial buildings, cinemas, theatres, auditoria, hotel rooms, restaurants, cafeterias, bars, gymnasia and premises of similar characteristics



IDA 4

Low quality air

EXTERNAL AIR QUALITY CLASSIFICATION

The quality of external air used to bring air into the interior of the building will be classified in accordance with the levels listed below.



ODA 1

Pure air which may temporarily contain solid particles



ODA 2

Air with high concentrations of particles



ODA 3

Air with high concentrations of gaseous contaminants



ODA 4

Air with high concentrations of gaseous contaminants and particles



ODA 5

Air with very high concentrations of gaseous contaminants and particles

FILTRATION NEEDS

The minimum filtration needs to be used will be calculated according to the required internal air quality and the quality of the external air.

	 IDA 1 Prefilter / Filter	 IDA 2 Prefilter / Filter	 IDA 3 Prefilter / Filter	 IDA 4 Prefilter / Filter
 ODA 1	F7/F9	F6/F8	F6/F7	G4/F6
 ODA 2	F7/F9	F6/F8	F6/F7	G4/F6
 ODA 3	F7/F9	F6/F8	F6/F7	G4/F6
 ODA 4	F7/F9	F6/F8	F6/F7	G4/F6
 ODA 5	F6/GF/F9* F9	F6/GF/F9* F8	F6/F7	G4/F6

(*) GF: Chemical filter between the two stages of filtration



Regulation on heating installations in buildings

EXAMPLES OF INSTALLATION

Graphic solutions for the fulfilment of minimum filtrations demanded by the R.I.T.E.

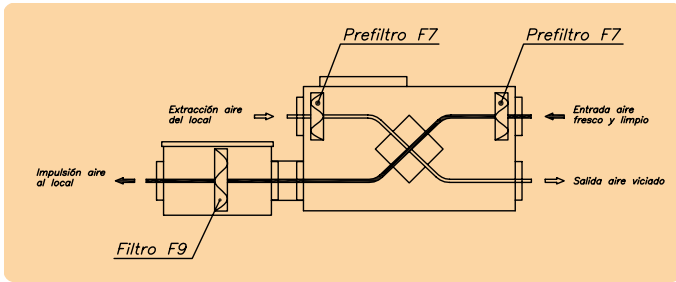

A

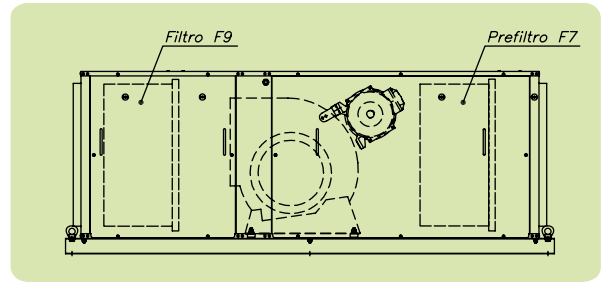

B

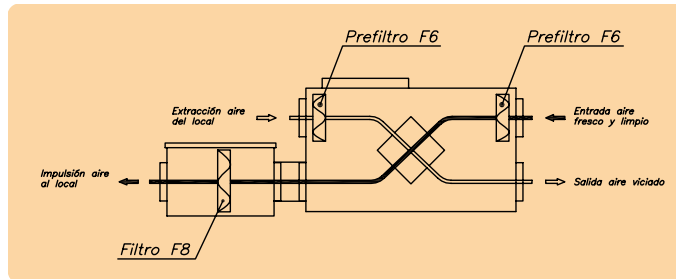

A

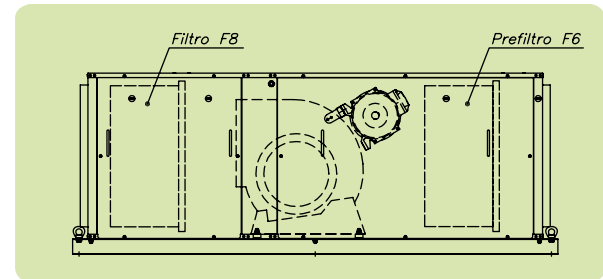

B

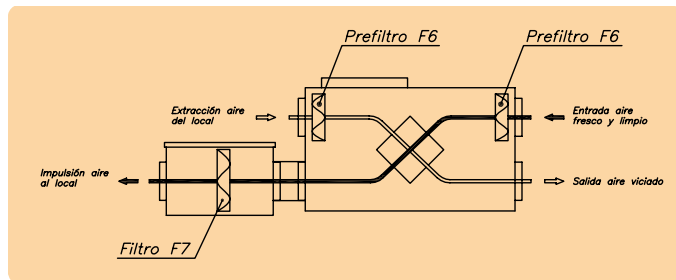

A

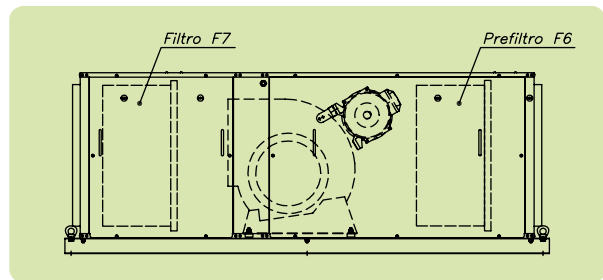

B

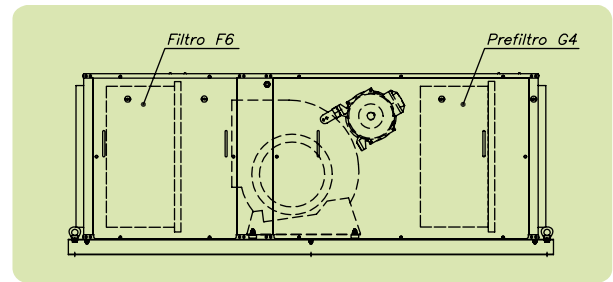
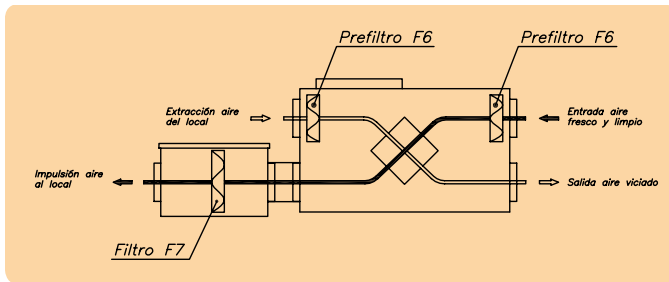

A*

B

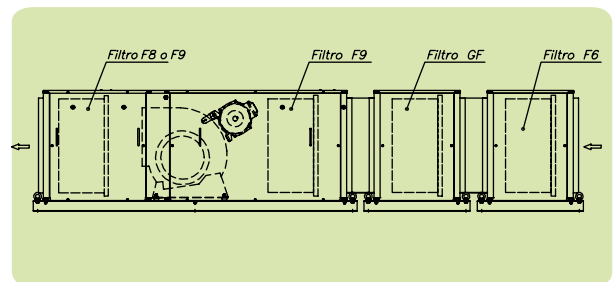
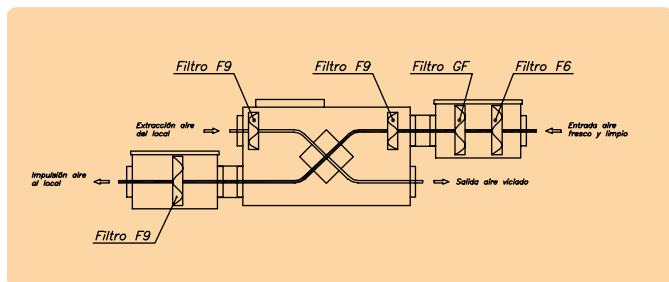

A**

B**

Translation of literals from the graph
 Extracción aire del local: Extraction of air from the premises
 Impulsión aire al local: Impulsion of air from the premises
 Entrada aire fresco y limpio: Entry of fresh, clean air
 Salida aire viciado: Outlet of used air
 Prefiltro F7: F7 Pre-Filter
 Prefiltro F6: F6 Pre-Filter
 Prefiltro G4: G4 Pre-Filter
 Filtro F6: F6 Filter
 Filtro F7: F7 Filter
 Filtro F8: F8 Filter
 Filtro F9: F9 Filter
 Filtro GF: GF Filter
 Filtro F8 o F9: F8 or F9 Filter

A: Solutions to the R.I.T.E. with heat recuperators or combinations of recuperators and filtration units
 B: Solutions to the R.I.T.E. with filtration units

* Filtration performance better than required by R.I.T.E.
 ** Construction on demand

SUMMARY OF HEAT RECUPERATORS



RIS H

High-efficiency heat recovery, with cross-flow plates and operation with automatic control Designed to be installed in a horizontal position

- High efficiency exchanger (54%-60%)
- Filters for high efficiency air supply F6, F7 or F9
- Electronics for automatic control, integrated in 400 to 1900 models
- Double soundproofed wall with 20-30-50 mm. of sound insulation according to model
- Maximum flows from 450 m³/h to 6600 m³/h
- Versions:

- Environmental: Renewal of air without supply of heat
- Electrical: With supply of heating by electric batteries
- Water battery: With supply of heating by water batteries
- On request: Adiabatic module



RIS V

High-efficiency heat recovery, with cross-flow plates and operation with automatic control Design for vertical installation

- High efficiency exchanger (54%-60%)
- Filters for high efficiency air supply F6, F7 or F9
- Electronics for automatic control, integrated in 260 to 1900 models
- Double soundproofed wall with 20-30-50 mm. of sound insulation according to model
- Maximum flows from 290 m³/h to 2.150 m³/h
- Versions:

- Environmental: Renewal of air without supply of heat
- Electrical: With supply of heating by electric batteries
- Water battery: With supply of heating by water batteries
- On request: Adiabatic module

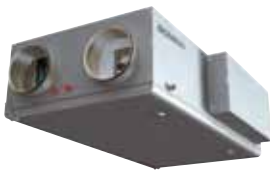
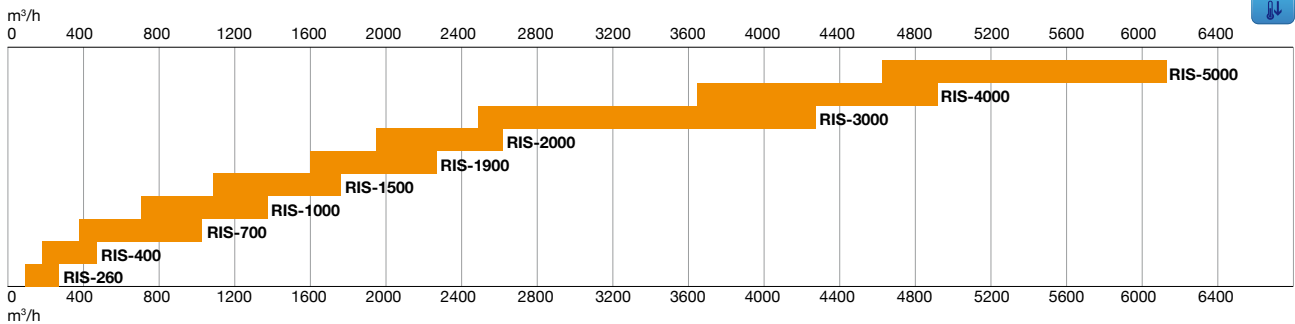

RIS P

Highly efficient heat recuperators with crossed flow plates and operation with automatic control, design for horizontal installation and especially for false ceilings

- High efficiency exchanger (54%-75%)
- Filters for high efficiency air supply F6, F7 or F9
- Electronics for automatic control, integrated in 400 to 1900 models
- Double soundproofed wall with 20-30-50 mm. of sound insulation according to model
- Maximum flows from 450 m³/h to 4.300 m³/h
- Versions:

- Environmental: Renewal of air without supply of heat
- Electrical: With supply of heating by electric batteries
- Water battery: With supply of heating by water batteries
- On request: Adiabatic module

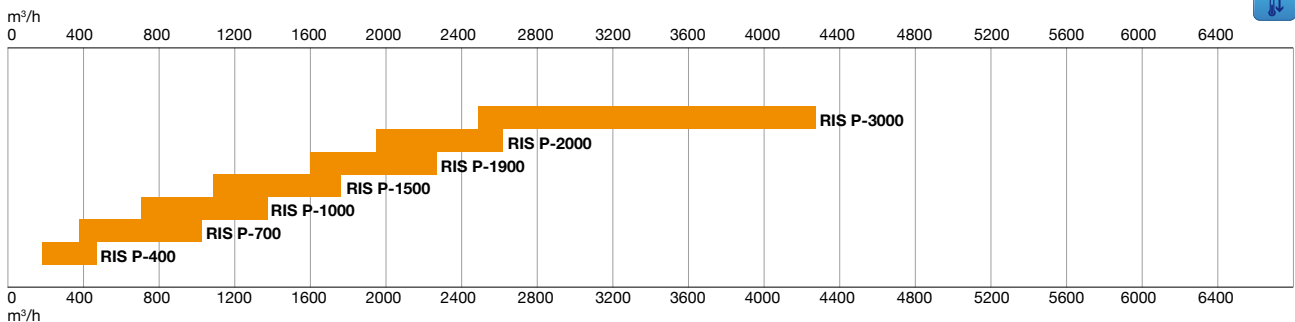



RECUP

Configurable heat recuperators with crossed flow plates, for horizontal installation (H)



- Exchanger with aluminium plates with efficiency between 52% and 55%
- Air supply filters F6 or F6+F8
- Galvanised steel box with built-in soundproofing
- Maximum flows from 500 m³/h to 6100 m³/h
- Versions:
 - Environmental: Renewal of air without supply of heat
 - On request: Adiabatic module

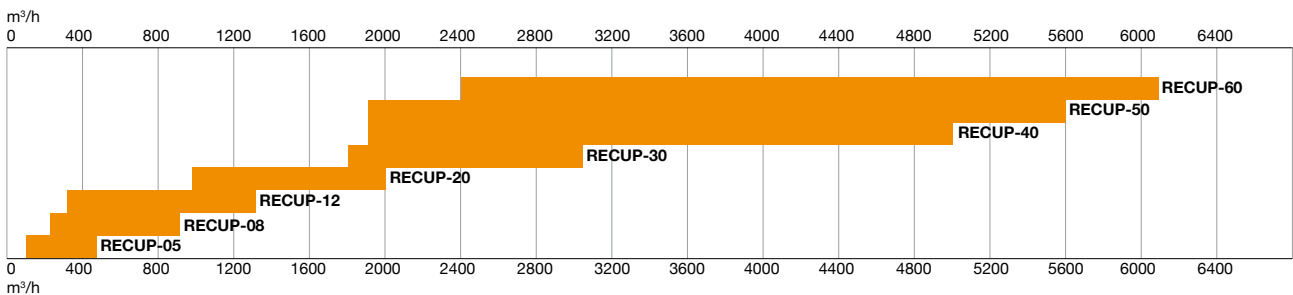

RIRS

Very highly efficient heat recuperators with rotating exchanger and operation with automatic control. Designed to be installed in a horizontal position



- High efficiency rotational exchanger (70%-77%)
- Filters for F7 high efficiency air supply
- Electronics for automatic control, integrated in 400 to 1500 models
- Double soundproofed wall with 50 mm. of sound insulation
- Maximum flows from 425 m³/h to 6700 m³/h
- Versions:
 - Environmental: Renewal of air without supply of heat
 - Electrical: With supply of heating by electric batteries
 - Water battery: With supply of heating by water batteries

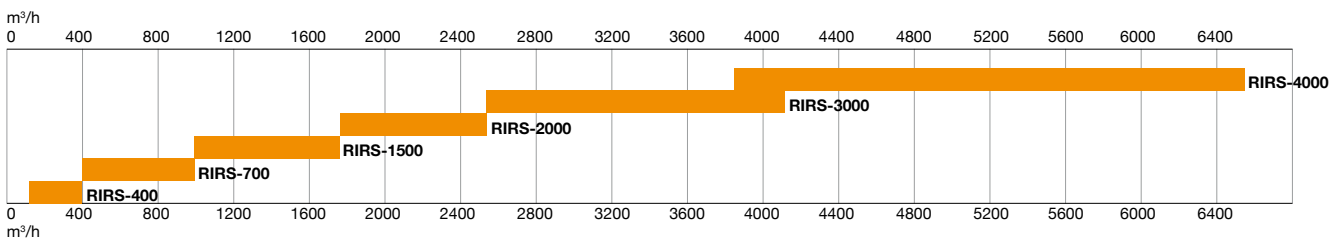

Accessories



CJFILTER

Air filter boxes for circular ducts equipped with different types of filter, according to model.

CJFILTER 100 F6

Diameter: 100 / 125 / 150 / 200 / 250 / 315 / 355 / 400
 Filters: G4 / F5 / F6 / F7 / F8 / F9



ADIABATIC BOX

Box which incorporates an adiabatic module. It contributes to the cooling of the air supply to the premises. It is installed in the extraction circuit between the pre-filter and the exchanger.

Accessories

See accessories section

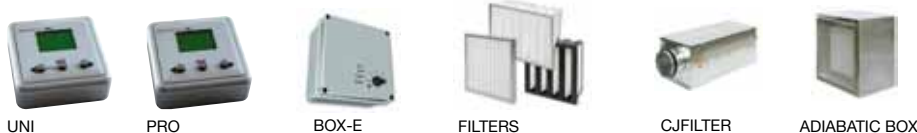

SUMMARY FILTRATION UNITS

SV/FILTER

Low noise in-line duct fans with different stages of filtration



- Acoustic casing covered with sound absorbing material.
- Standard aspiration and impulsion joints to aid in duct installation.
- G4 + F6, F6 + F8 and F7 + F9 filters according to model
- Easy access inspection and cleaning cover



G4 + F6

F6 + F8

F7 + F9

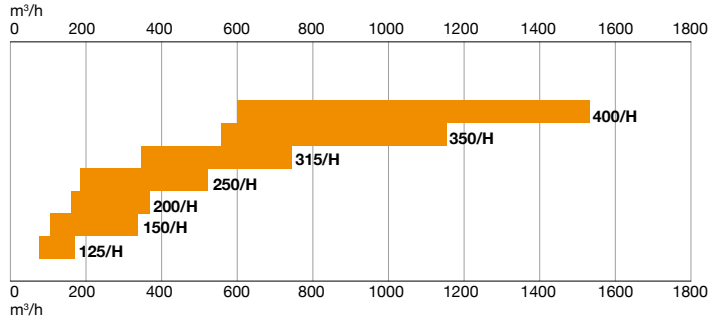

UFR

Soundproofed filtration units with sandwich panel, equipped with high-performance reaction turbine fans and different stages of filtration according to model



- Activation with a direct motor
- Built-in general bed
- F6 + F8, F7 + F9 and G4 + F6 filters according to model selected
- Possibility of pre-filter plus two stages of filtration
- Pressure inlets for filter control
- Built-in pressure probe



F6 + F8

F7 + F9

G4 + F6

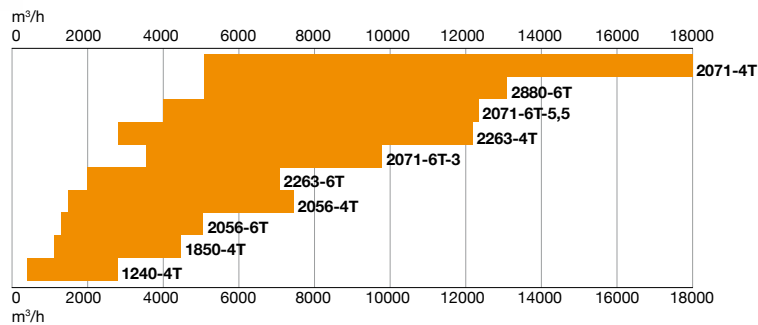



UFX

Soundproofed filtration units equipped with double inlets and different stages of filtration according to model.

- Belt-driven
- Built-in general bed
- F6 + F8, F7 + F9 and G4 + F6 filters according to model selected
- Possibility of pre-filter plus two stages of filtration
- Easy access inspection and cleaning cover
- Pressure inlets for filter control
- Built-in pressure probe

F6 + F8

F7 + F9

G4 + F6

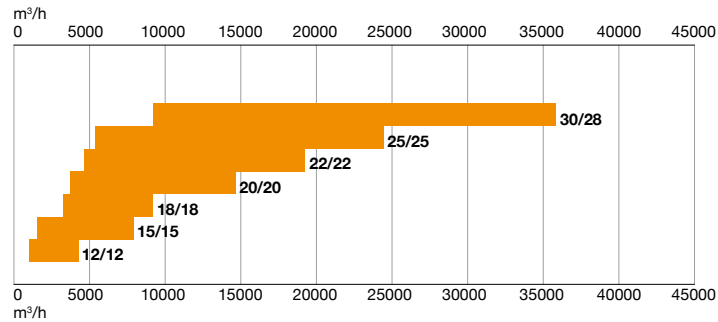

UFRX

Soundproofed filtration units equipped with double inlet fans and very robust reaction turbine and different stages of filtration according to model.

- Belt-driven
- Built-in general bed
- F6 + F8, F7 + F9 and G4 + F6 filters
- Possibility of pre-filter plus two stages of filtration
- Easy access inspection and cleaning covers
- Pressure inlets and pressure probe for filter control
- On request: Absolute active carbon filters



F6 + F8

F7 + F9

G4 + F6

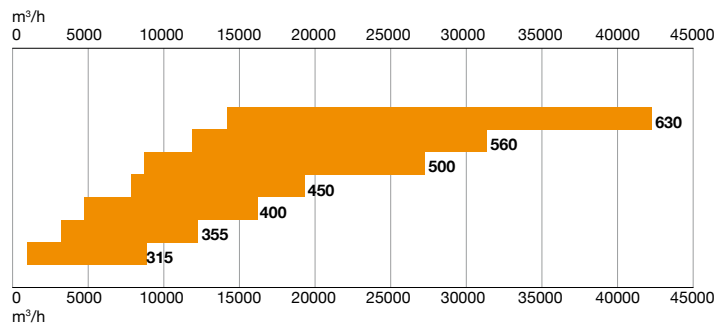

Accessories

See accessories section



FILTERS



C-J FILTER



PRESOSTATO



SI-PRESSURE



CONSTANT FLOW KIT



PRESSURE PROBE



INT



VIS



TEJ



GENERAL BEDPLATE



SILENT-BLOCKS

RIS H/V

Highly efficient heat recuperators with crossed flow plates for automatic operation and control of the recuperator, according to selected parameters of temperature and humidity (models 260 to 1900). Designed for horizontal (H) or vertical (V) installation



UNI Controller included in RIS 260 to RIS 1900 models

Features:

- High efficiency exchanger (54%-60%)
- Filters for high efficiency air supply F6, F7 or F9
- Electronics for automatic control, integrated in 260 to 1900 models with UNI controller included
- Electronic for automatic control, as an accessory (BOX-E) in models 2000 to 5000, for the control it is necessary to request the UNI or PRO panel as an accessory
- Double soundproofed wall with 50 mm of high absorption soundproofing (models 260 with 20 mm and models 400-700 with 30 mm)
- Input and output temperature sensor (size 1000 to 1900)
- Humidity sensor according to model (size 1000 to 1900)
- Built-in bypass hatch
- Tray for collecting condensation in stainless steel and with drainage valve

Construction:

- Metallic structure

- Double-wall panels, with soundproofing of 30-50 mm. thickness
- Input and output vents with airtight joint
- Large access doors to facilitate maintenance and cleaning. In the horizontal version, the doors are exchangeable so as to be able to carry out the maintenance on the right and the left, seen through the vents.

Versions:

- Horizontal (H) or Vertical (V)
- Vertical up to size 1900 (V)
- Environmental: Renewal of air without supply of heat (S)
- Electric: With supply of heating by electric batteries (E)
- Water battery: With supply of heating by water batteries (W)
- On request: Adiabatic module



Order code

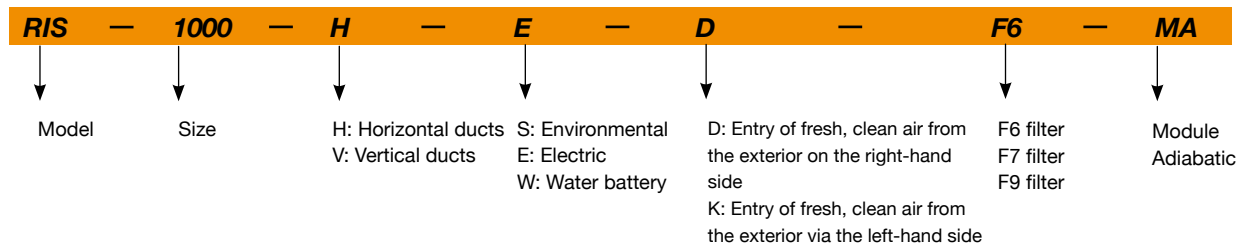

Accessories

See accessories section



Technical characteristics

Model	Speed (r/min)	Voltage (V)	Current (A)	Power motor (W)	Max Airflow F6(m³/h)	Max. Airflow F7(m³/h)	Thermal efficiency (%)	Irradiated NPS dB(A)	Current Total (A)	Filter EN 779	Weight (Kg)	Electrical B.		Water B.
												Voltage (V)	Resistance Power (kW)	Thermal power (kW)
RIS-400S	2100	1x230	2x1.1	2x225	450		60	34		F6/F7	47			
RIS-700S	2000	1x230	2x1.12	2x255	950		60	41		F6/F7	62			
RIS-1000S	2650	1x230	2x0.81	2x185	1300	1180	54	42		F6/F7	149			
RIS-1500S	2750	1x230	2x1.23	2x280	1650	1450	54	44		F6/F7	179			
RIS-1900S	2830	1x230	2x2.7	2x610	2150	2030	60	46		F6/F7	308			
RIS-2000S	1310	3x400	2x2.6	2x1500	2600	2470	60	49		F6/F7	324			
RIS-3000S	1300	3x400	2x4.1	2x2500	4300	3760	59	50		F6/F7	393			
RIS-4000S	2090	3x400	2x4.7	2x2200	5000	3850	58	51		F6/F7	498			
RIS-5000S	1867	3x400	2x6.47	2x3000	6000	4680	58	52		F6/F7	568			
RIS-260E	1880	1x230	2x0.4	2x89	280		55	31	6.4	F6/F7	40	1x230	1	
RIS-400E	2100	1x230	2x1.1	2x225	450		60	34	14.8	F6/F7	48	1x230	2	
RIS-700E	2000	1x230	2x1.12	2x255	950		60	41	20.5	F6/F7	70	1x230	3	
RIS-1000E	2650	1x230	2x0.81	2x185	1300	1180	54	42	10.6	F6/F7	150	3x400	6	
RIS-1500E	2750	1x230	2x1.23	2x280	1650	1450	54	44	16.2	F6/F7	180	3x400	9	
RIS-1900E	2830	1x230	2x2.7	2x610	2150	2030	60	46	27	F6/F7	310	3x400	15	
RIS-2000E	1310	3x400	2x2.6	2x1500	2600	2470	60	49	26.9	F6/F7	328	3x400	15	
RIS-3000E	1300	3x400	2x4.1	2x2500	4300	3760	59	50	44.7	F6/F7	395	3x400	24	
RIS-4000E	2090	3x400	2x4.7	2x2200	5000	3850	58	51	50.4	F6/F7	500	3x400	27	
RIS-5000E	1867	3x400	2x6.47	2x3000	6000	4680	58	52	63.1	F6/F7	570	3x400	33	
RIS-400W	2100	1x230	2x1.1	2x225	450		60	34		F6/F7	52			2.7*
RIS-700W	2000	1x230	2x1.12	2x255	950		60	41		F6/F7	63			4.7*
RIS-1000W	2650	1x230	2x0.81	2x185	1300	1180	54	42		F6/F7	150			6.75*
RIS-1500W	2750	1x230	2x1.23	2x280	1650	1450	54	44		F6/F7	180			10.12*
RIS-1900W	2830	1x230	2x2.7	2x610	2150	2030	60	46		F6/F7	310			12.82*
RIS-2000W	1310	3x400	2x2.6	2x1500	2600	2470	60	49		F6/F7	326			15.6*
RIS-3000W	1300	3x400	2x4.1	2x2500	4300	3760	59	50		F6/F7	395			20.2*
RIS-4000W	2090	3x400	2x4.7	2x2200	5000	3850	58	51		F6/F7	500			26.0*
RIS-5000W	1867	3x400	2x6.47	2x3000	6000	4680	58	52		F6/F7	570			32.0*

* Values measured with exterior air temperature of +18°C and water temperature of Tin/Tout 80/60 °C

Configurations

Configuration D standard supply

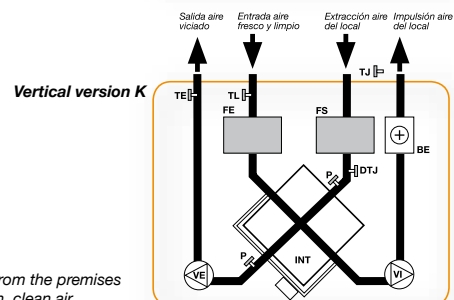
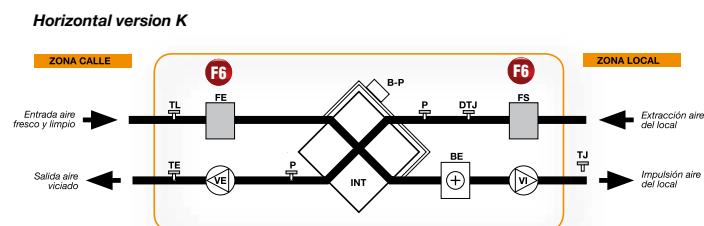
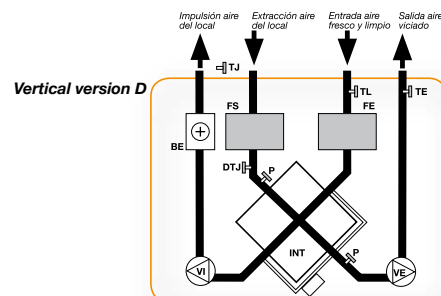
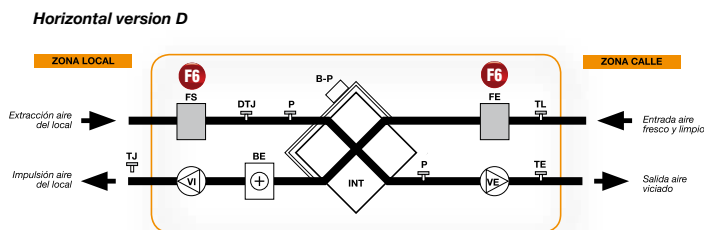

Translation of literals from the graph

ZONA LOCAL: LOCAL AREA

ZONA CALLE: STREET AREA

Extracción aire del local: Extraction of air from the premises

Impulsión aire del local: Impulsion of air from the premises

Entrada aire fresco y limpio: Entry of fresh, clean air

Salida aire viciado: Outlet of used air

Dimensions in mm

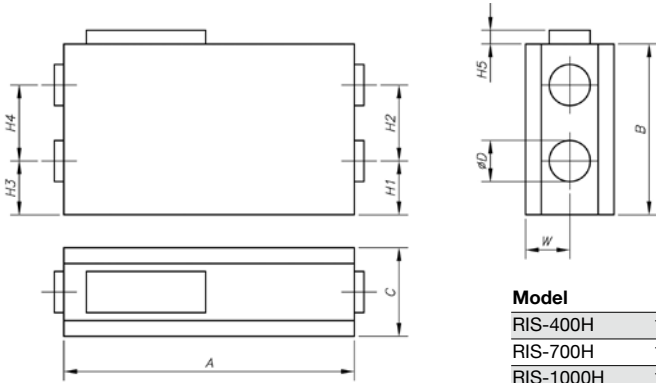

Model	A	B	C	Ø D	H1	H2	H3	H4	H5	W
RIS-400H	1170	600	354	160	250	190	250	190	55	200
RIS-700H	1320	600	504	250	150	310	150	310	55	252
RIS-1000H	1500	905	645	315	233	400	233	400	-	-
RIS-1500H	1500	905	645	315	233	400	233	400	-	-
RIS-1900H	1800	1120	790	400	275	500	275	500	-	-
RIS-2000H	2100	1050	790	400	265	510	265	510	-	395
RIS-3000H	2400	1130	830	400	350	500	350	500	-	300

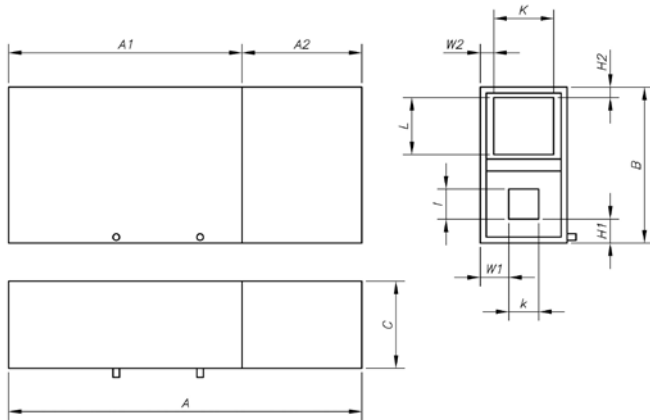

Model	A	A1	A2	B	C	H1	H2	K	k	L	I	W1	W2
RIS-4000H	3000	2000	1000	1244	584	178	35	500	260	500	260	162	36
RIS-5000H	3000	2000	1000	1242	832	191	34	710	332	562	332	412	87

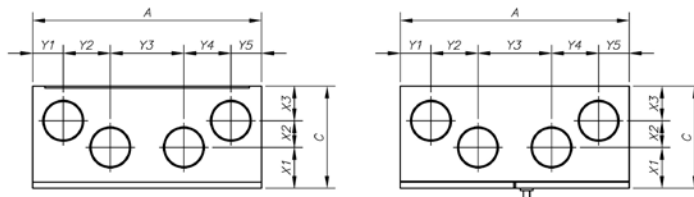
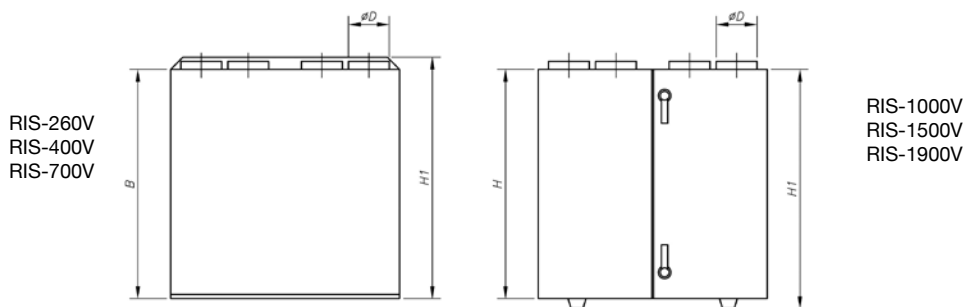

Model	A	B	C	Ø D	H1	X1	X2	X3	Y1	Y2	Y3	Y4	Y5
RIS-260V	598	640	295	125	690	135	70	90	90	129	160	129	90
RIS-400V	900	800	352	160	850	166	60	126	130	205	230	205	130
RIS-700V	950	845	462	200	895	182	120	160	140	212	246	212	140
RIS-1000V	1400	1000	645	315	1070	250	187	208	207	328	330	328	207
RIS-1500V	1400	1000	645	315	1070	250	187	208	210	325	330	325	210
RIS-1900V	1650	1100	790	400	1170	292	248	250	225	395	410	395	225

Characteristic curves

RIS-260 / RIS-400 / RIS-700

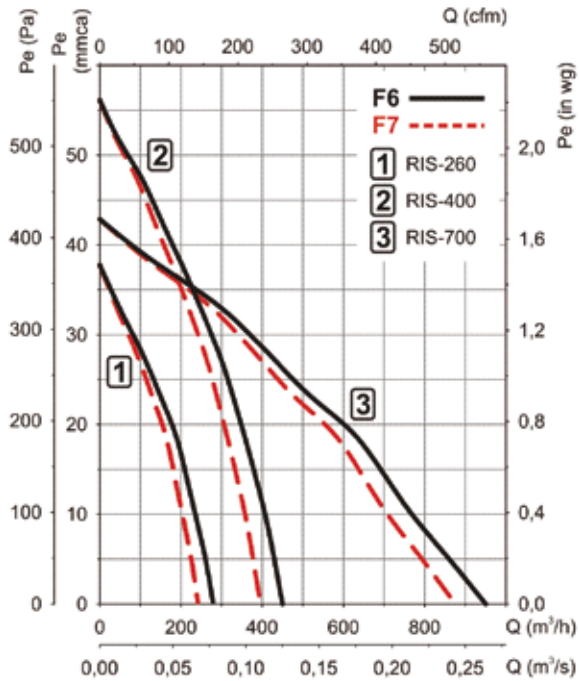

RIS-1000 / RIS-1500 / RIS-1900

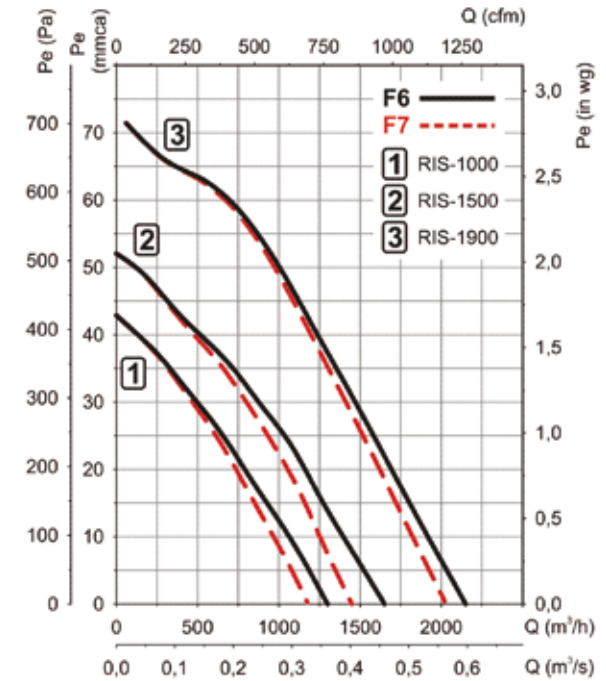

RIS-2000 / RIS-3000

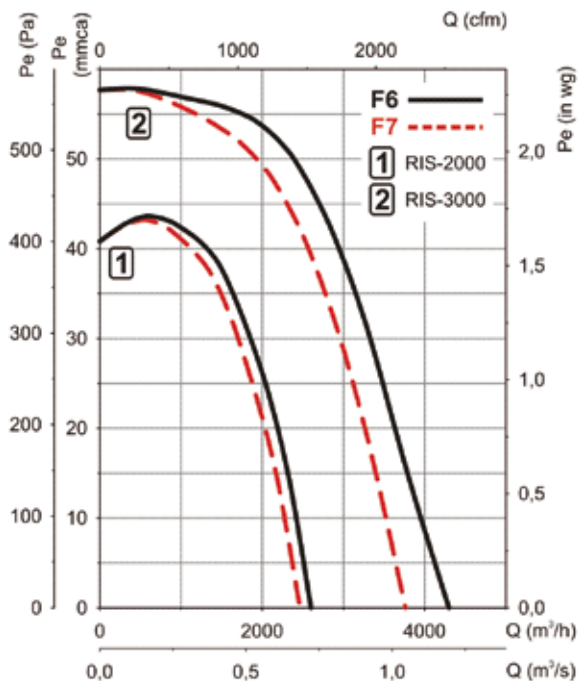

RIS-4000 / RIS-5000

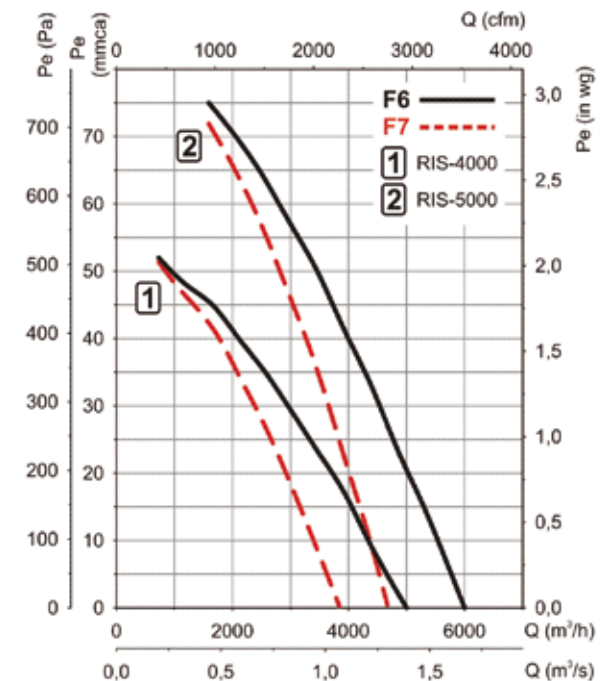

RIS P

Efficiency heat recoveries and low silhouette, for automatic operation and control of the recuperator. Designed for horizontal installation in false ceilings.



UNI Controller included from RIS-400 to RIS-1900 equipments

General characteristics:

- High efficiency exchanger (54%-75%)
- 2 Air filters of F6, F7 efficiencies made with low-loss loading bags (F9, please consult).
- Electronics for automatic control, integrated in 260 to 1900 models with UNI controller included.
- Electronic for automatic control, as an accessory (BOX-E) in models 2000 to 3000, for the control it is necessary to request the UNI or PRO panel as an accessory.
- Input and output temperature sensors (size 400 to 1900)
- Humidity sensor, size 1000 to 1900.
- Built-in bypass hatch in models 1000 to 3000.
- Bypass automatic control in models 1000 to 1900.

30 mm. thickness in 400 and 700, and 60 mm. in the rest.

- Input and output vents with airtight joint
- Lower access doors to facilitate maintenance and cleaning.

Versions:

- Horizontal: For false ceiling
- Environmental: Renewal of air without supply of heat (S)
- Electric: With supply of heating by electric batteries (E)

On request:

- Adiabatic module
- 2 configurations of outlets according to model (see diagrams of D or K configurations)



Construction:

- Metallic structure
- Double-wall panels, with soundproofing of



Impeller detail



Filters detail

Order code

RIS	—	400	—	P	—	E	—	D	—	F6	—	MA
↓		↓		↓		↓		↓		↓		↓
Model		Size		Flat design for suspended ceiling		S: Environmental E: Electric		D: Entry of air from the exterior on the right-hand side K: Entry of air from the exterior on the left-hand side		F6 filter F7 filter F9 filter		Adiabatic module

Technical characteristics

Model	Fans				Max. Airflow F6(m³/h)	Max. Airflow F7(m³/h)	Thermal efficiency (%)	Irradiated NPS dB(A)	Total current (A)	Filter EN 779	Weight (Kg)	Electrical B.	
	Speed (r/min)	Voltage (V)	Current (A)	Power (W)								Voltage (V)	Resistance power (kW)
RIS-1000-P-S	2250	1x230	2x1.36	2x312	1300	1180	51	42	2.61	F6/F7	113		
RIS-1500-P-S	2750	1x230	2x1.63	2x373	1650	1450	62	44	3.2	F6/F7	189		
RIS-1900-P-S	2830	1x230	2x2.95	2x669	2150	2030	60	46	5.9	F6/F7	290		
RIS-2000-P-S	1310	3x400	2x1.94	2x885	2600	2470	60	49	3.88	F6/F7	324		
RIS-3000-P-S	1300	3x400	2x2.58	2x1388	4300	3760	59	50	5.05	F6/F7	393		
RIS-400-P-E	1850	1x230	2x0.77	2x174	500	450	75	44	14.52	F6/F7	42	1x230	2
RIS-700-P-E	2000	1x230	2x0.92	2x212	750	650	57	45	20.1	F6/F7	57	1x230	3
RIS-1000-P-E	2250	1x230	2x1.36	2x312	1300	1180	51	42	11.27	F6/F7	113	3x400	6
RIS-1500-P-E	2750	1x230	2x1.63	2x373	1650	1450	62	44	16.19	F6/F7	194	3x400	9
RIS-1900-P-E	2830	1x230	2x2.95	2x669	2150	2030	60	46	27.55	F6/F7	310	3x400	15
RIS-2000-P-E	1310	3x400	2x1.94	2x885	2600	2470	60	49	25.53	F6/F7	328	3x400	15
RIS-3000-P-E	1300	3x400	2x2.58	2x1388	4300	3760	59	50	44.7	F6/F7	395	3x400	24

Notes: * Thermal efficiencies calculated with a temperature differential +20 °C inside / -20 °C outside, 60% internal humidity, 90% external humidity.

* Irradiated sound pressure level are free field at 1.5 m * Equipment with a fan or three-phase battery should be connected with three phases + neutral + earth.

Configurations

Configuration D standard supply.

Diagrams according to top view (the opposite side to the inspection door).

K version only available for 1900, 2000 and 3000 models.

Horizontal version D

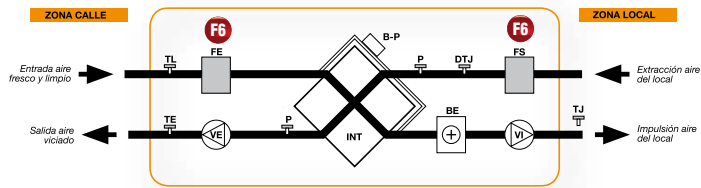

Horizontal version K

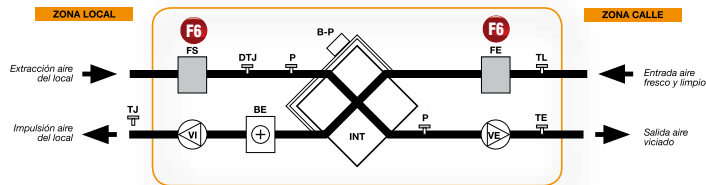

Translation of literals from the graph

ZONA LOCAL: LOCAL AREA

ZONA CALLE: STREET AREA

Extracción aire del local: Extraction of air from the premises

Impulsión aire del local: Impulsion of air from the premises

Entrada aire fresco y limpio: Entry of fresh, clean air

Salida aire viciado: Outlet of used air

Dimensions in mm

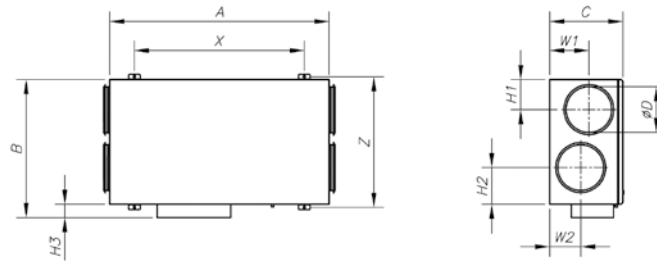

Model	A	B	C	ØD	H1	H2	H3	W1	W2	X	Z
RIS-400-P	970	615	264	160	125	120	75	125	140	830	592
RIS-700-P	1200	775	300	250	190	190	75	134	134	1040	752
RIS-1000-P	1500	943	495	315	206	206	93	245	245	1124	890

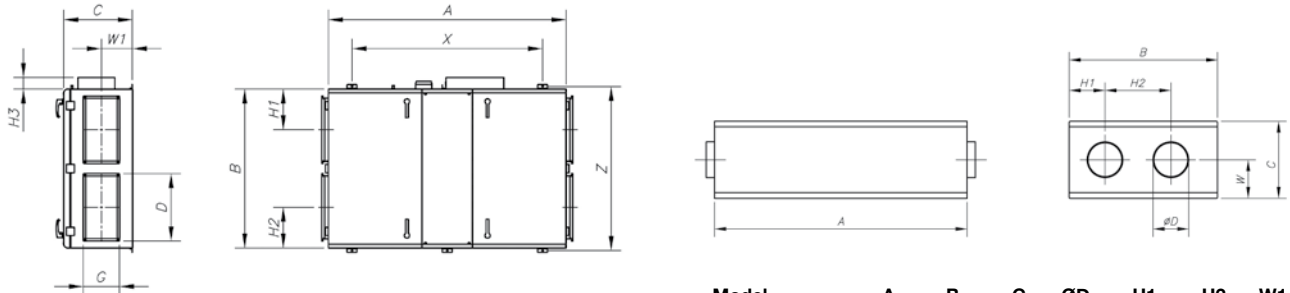

Model	A	B	C	D	G	H1	H2	H3	W1	X	Z
RIS-1500-P	1900	1363	549	500	250	325	325	93	248	1524	1310

Model	A	B	C	ØD	H1	H2	W1
RIS-1900-P	1800	1120	790	400	275	500	395
RIS-2000-P	2100	1080	790	400	280	520	395

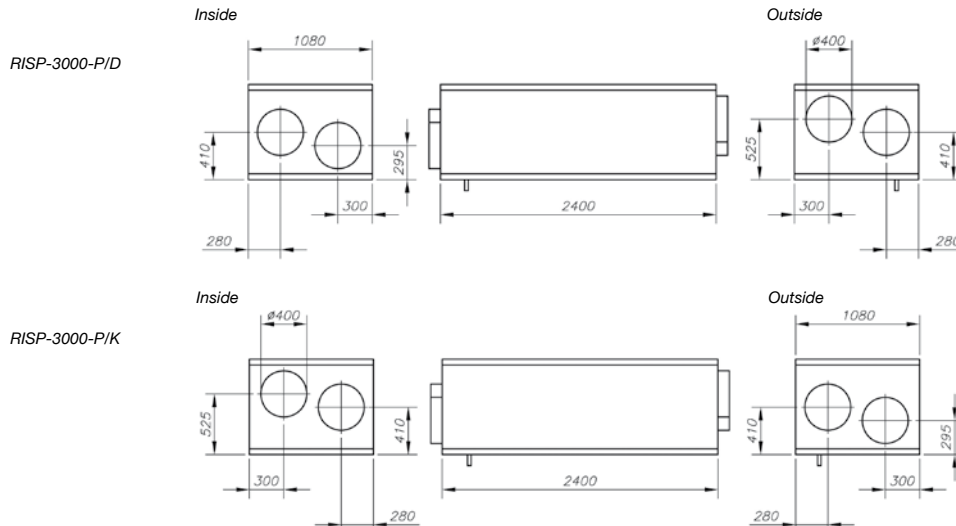

Characteristic curves

RIS P-400E / RIS P-700E

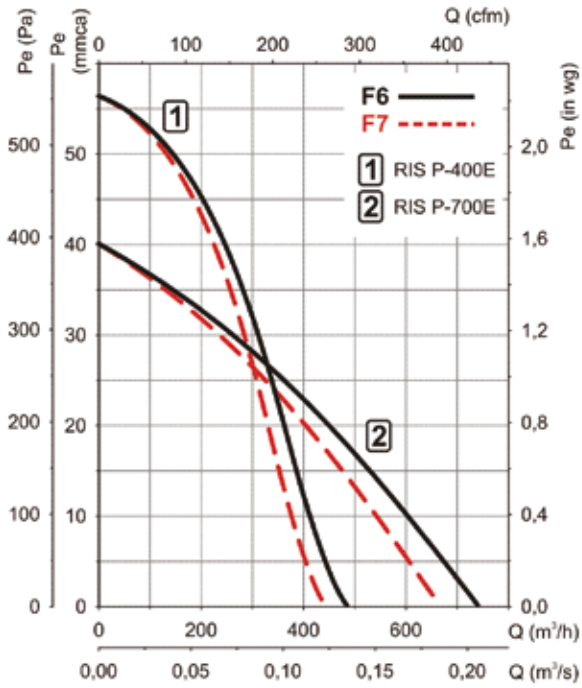

RIS P-1000 / RIS P-1500 / RIS P-1900

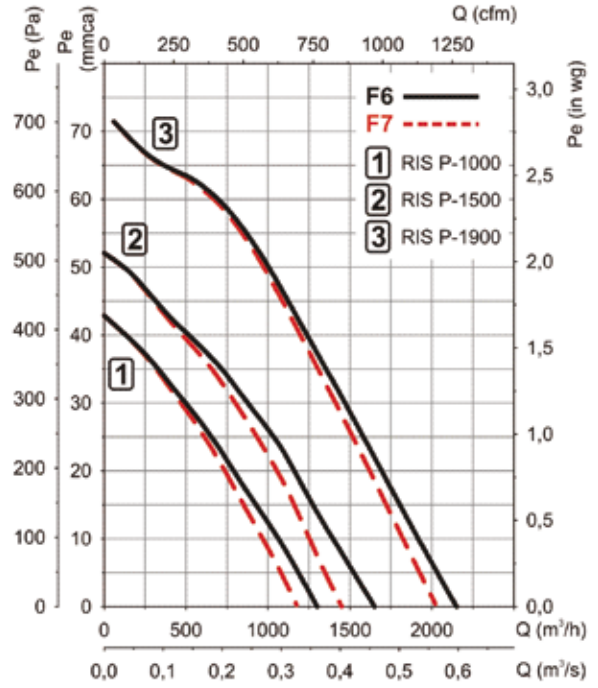

RIS P-2000 / RIS P-3000

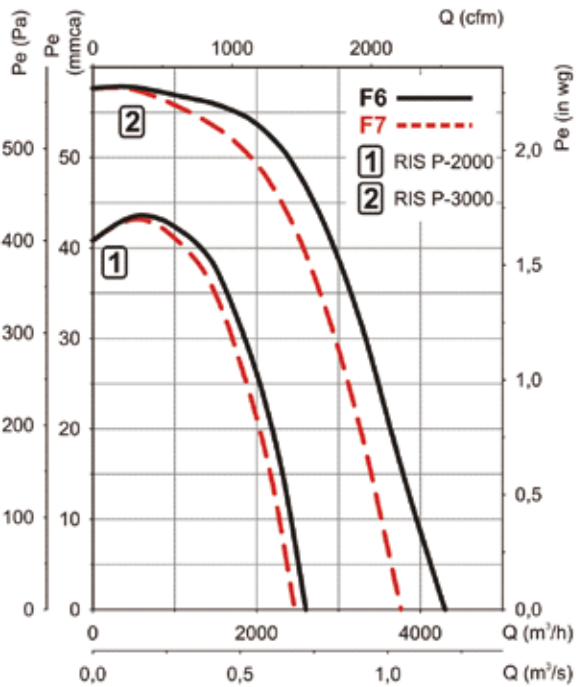

Accessories

See accessories section



Configurations (Horizontal version)

Configuration C standard supply. Except models 05, 08 and 12 configuration B.

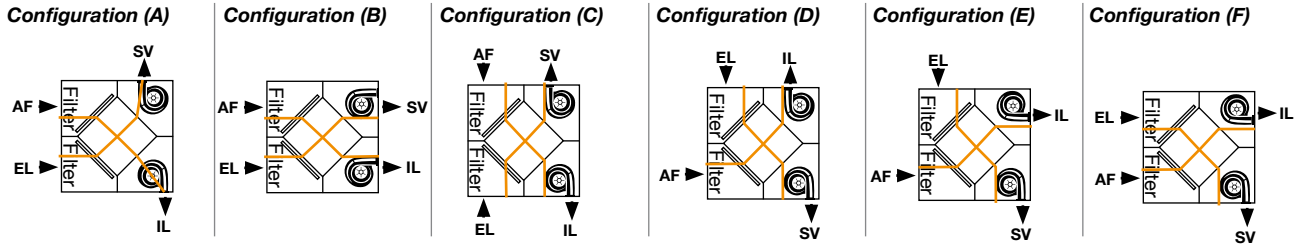

AF: External fresh air / IL: Impulsion of air to the premises / SV: Outlet of used air / EL: Extraction of air from the premises

Dimensions in mm

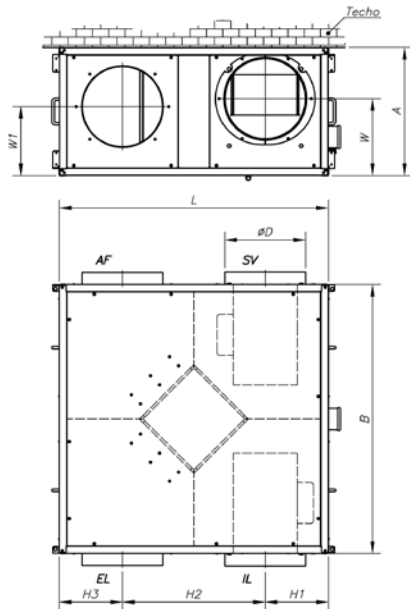

Models	A	B	L	$\varnothing D$	H1	H2	H3	W	W1	Weight (Kg)
RECUP-05-H	324.5	630	630	200	167.5	295	167.5	148	148	33
RECUP-08-H	346	800	800	250	210	380	210	181	181	45
RECUP-12-H	396	1000	1000	315	235	530	235	198	198	67
RECUP-20-H	500	1020	1020	315	246.5	557	246.5	300	269	86
RECUP-30-H	600	1102	1202	315	270	662	270	385	368	112
RECUP-40-H	670	1500	1500	450	344.5	811	344.5	379	379	167
RECUP-50-H	805	1500	1700	450	347	1006	347	440	402.5	182
RECUP-60-H	805	1500	1700	450	347	1006	347	440	402.5	195

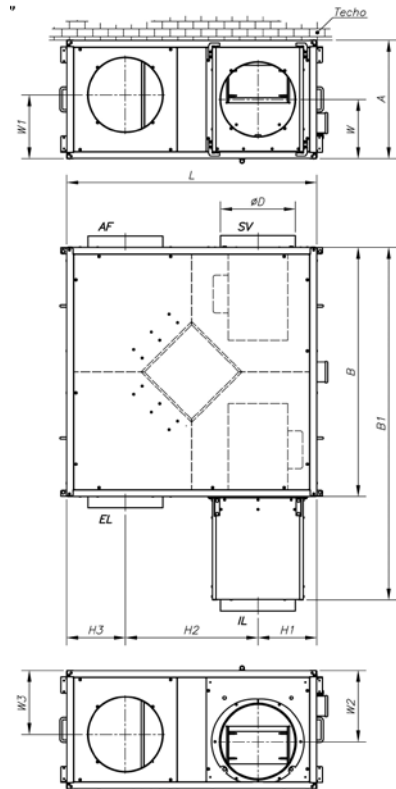

Models	A	B	B1	L	$\varnothing D$	H1	H2	H3	W	W1	W2	W3
RECUP-05-H	300	630	1062	628	200	171	286	171	150	150	150	150
RECUP-08-H	350	800	1232	800	250	200	400	200	175	175	175	175
RECUP-12-H	415	1000	1432	1000	315	250	500	250	207.5	207.5	207.5	207.5
RECUP-20-H	500	1050	1486	1050	315	246.5	557	246.5	250	269	300	269
RECUP-30-H	600	1102	1540	1202	315	270	662	270	300	369	385	368
RECUP-40-H	670	1500	1931	1500	450	344.5	811	344.5	335	378.5	378	378.5
RECUP-50-H	805	1500	1931	1700	450	347	1006	347	402.5	402.5	440	402.5
RECUP-60-H	805	1500	1931	1700	450	347	1006	347	402.5	402.5	440	402.5

Dimensions in mm

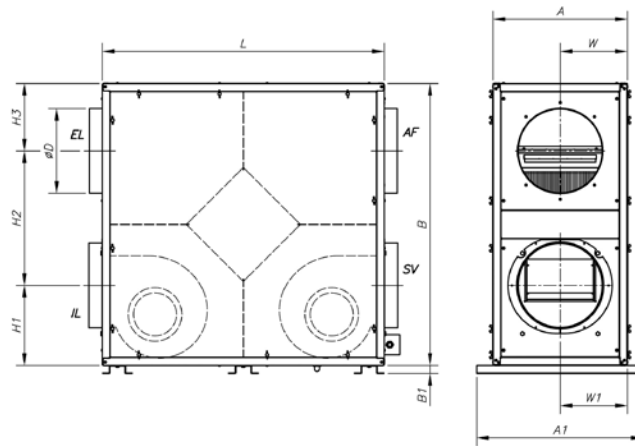

Models	A	A1	B	B1	L	øD	H1	H2	H3	W	W1
RECUP-20-V	500	620	1050	30	1050	315	298	501	251	250	250
RECUP-30-V	600	720	1202	30	1102	315	384	548	270	300	300
RECUP-40-V	670	790	1500	30	1500	450	391.5	739	369.5	334	335
RECUP-50-V	805	925	1700	30	1500	450	441	912	347	402.5	402.5
RECUP-60-V	805	925	1700	30	1500	450	441	912	347	402.5	402.5

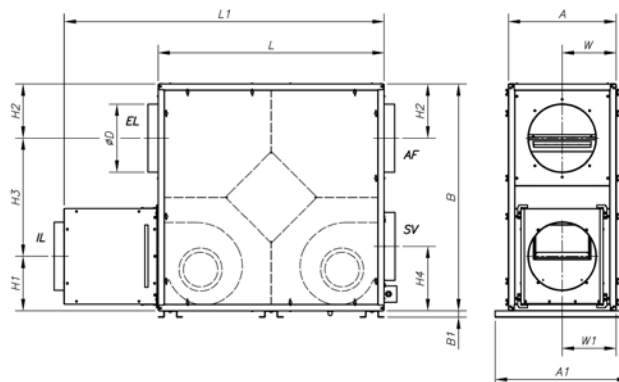

Models	A	A1	B	B1	L	L1	øD	H1	H2	H3	H4	W	W1
RECUP-20-V	500	620	1050	30	1050	1487	315	252	501	251	298	250	250
RECUP-30-V	600	720	1202	30	1102	1540	315	335	548	270	384	300	300
RECUP-40-V	670	790	1500	30	1500	1933	450	369.5	739	369.5	391.5	334	335
RECUP-50-V	805	925	1700	30	1500	1933	450	403.5	912	347	441	402.5	402.5
RECUP-60-V	805	925	1700	30	1500	1933	450	403.5	912	347	441	402.5	402.5

Acoustic features

The specified values are determined according to free field measurements of sound levels in dB(A) at a distance not less than 1.5 m of equipment.

Sound power Lw(A) spectrum in dB(A) via frequency band in Hz.

Model	63	125	250	500	1000	2000	4000	8000	Model	63	125	250	500	1000	2000	4000	8000
RECUP-05	45	47	38	31	39	28	21	21	RECUP-30	54	56	50	51	48	43	35	31
RECUP-08	52	54	44	37	50	37	34	30	RECUP-40	49	51	43	37	36	30	29	15
RECUP-12	54	56	49	52	54	50	45	38	RECUP-50	57	59	50	44	42	36	37	22
RECUP-20	49	51	44	47	49	45	40	33	RECUP-60	59	61	52	46	44	38	39	24

Characteristic curves

RECUP-05 / RECUP-08 / RECUP-12 / RECUP-20

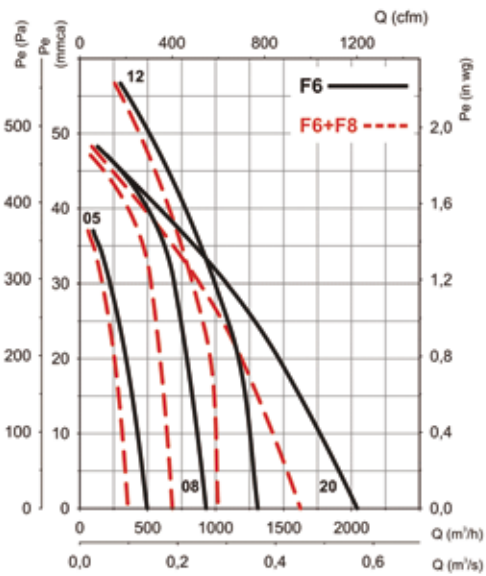

RECUP-30 / RECUP-40 / RECUP-50 / RECUP-60

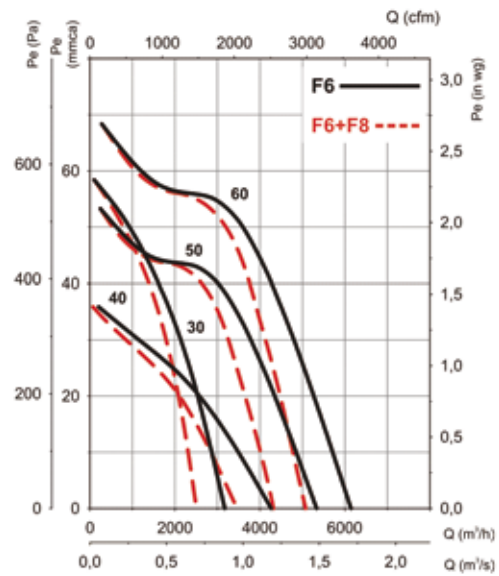

Accessories

See accessories section



RIRS

Very high efficiency heat recuperators with rotating exchanger for automatic operation and control of the recuperator, according to selected parameters of temperature and humidity (models 400 to 1500). Designed for horizontal (H) installation



UNI Controller included in RIRS 400 to RIRS 1500 models

Features:

- High efficiency exchanger (70%-77%)
- Filters for F7 high efficiency air supply
- Electronics for automatic control, integrated in 400 to 1500 models with UNI controller included
- Electronic for automatic control, as an accessory (BOX-E) in models 2000 to 4000, for the control it is necessary to request the UNI or PRO panel as an accessory
- Double soundproofed wall with 50 mm. of high-absorption sound insulation
- Fans with external rotor motor

Construction:

- Metallic structure
- Double-wall panels, with soundproofing of 50mm. thickness
- Exchangeable inspection plate.

- Input and output vents with airtight joint
- Large access doors to facilitate maintenance and cleaning. In the horizontal version, the doors are exchangeable up to 1500 model so as to be able to carry out the maintenance on the right and the left, seen through the vents.

Versions:

- Horizontal (H)
- Electric: With supply of heating by electric batteries (E)
- Water battery: With supply of heating by water batteries (W)



Order code

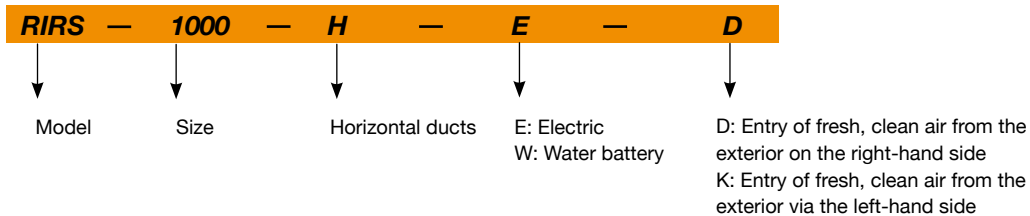

Technical characteristics

Model	Speed (r/min)	Voltage (V)	Current (A)	Power motor (W)	Max. Airflow (m³/h)	Thermal efficiency (%)	Irradiated NPS dB(A)	Total current (A)	Filter EN 779	Weight (Kg)	Electrical B.		Water B.
											Voltage (V)	Resistance power (kW)	Thermal power (KW)
RIRS-400E	1850	1x230	0.84	2x190	450	75	34	6.91	F7	70	1x230	1.2	
RIRS-700E	2050	1x230	1.31	2x300	950	74	41	11.39	F7	96	1x230	2	
RIRS-1500E	2750	1x230	1.71	2x390	1650	74	44	10.07	F7	159	3x400	4.5	
RIRS-2000E	1310	3x400	2.6	2x1500	2600	70	49	18.5	F7	260	3x400	9	
RIRS-3000E	1300	3x400	4.1	2x2500	4100	77	50	30.2	F7	410	3x400	15	
RIRS-4000E	1320	3x400	6	2x3700	6500	71	53	38.3	F7	490	3x400	18	
RIRS-1500W	2750	1x230	1.71	2x390	1650	74	44		F7	165			5.45
RIRS-2000W	1310	3x400	2.6	2x1500	2600	70	49		F7	260			9.5
RIRS-3000W	1300	3x400	4.1	2x2500	4100	77	50		F7	410			11.21
RIRS-4000W	1320	3x400	6	2x3700	6500	71	53		F7	490			16.29

Configurations

Configuration D standard supply

Horizontal version D

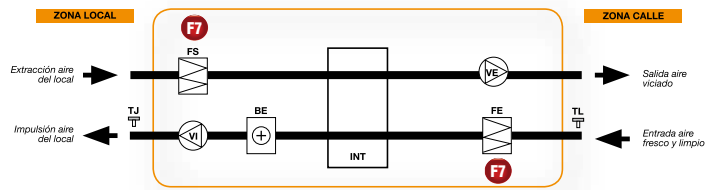

Translation of literals from the graph
ZONA LOCAL: LOCAL AREA
ZONA CALLE: STREET AREA
Extracción aire del local: Extraction of air from the premises
Impulsión aire del local: Impulsion of air from the premises
Entrada aire fresco y limpio: Entry of fresh, clean air
Salida aire viciado: Outlet of used air

Horizontal version K

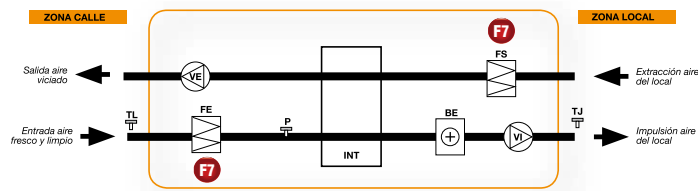

Dimensions in mm

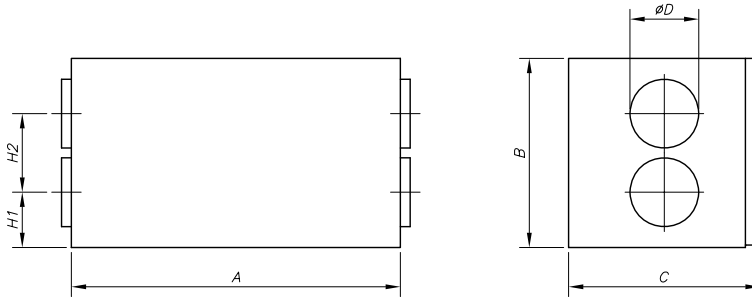

Model	A	B	C	Ø D	H1	H2
RIRS-400	1000	580	555	160	142	288
RIRS-700	1220	700	706	250	200	300
RIRS-1500	1800	900	906	315	239	422
RIRS-2000	1800	900	906	400	239	422
RIRS-3000	2100	1200	1205	400	318	564

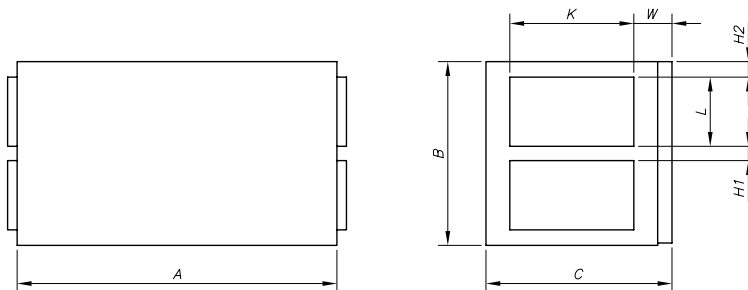

Model	A	B	C	H1	H2	K	L	W
RIRS-4000	2100	1200	1205	60	70	800	500	226

Characteristic curves

RIRS 400HE / RIRS 700HE / RIRS 1500HE

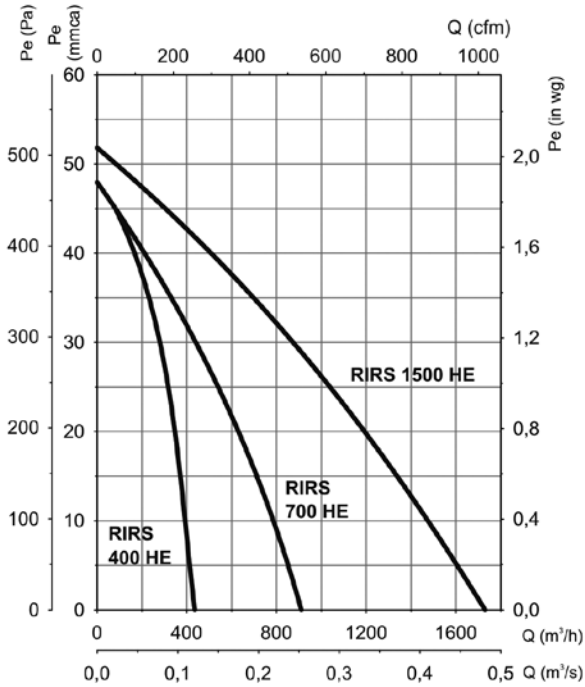

RIRS 1500HW

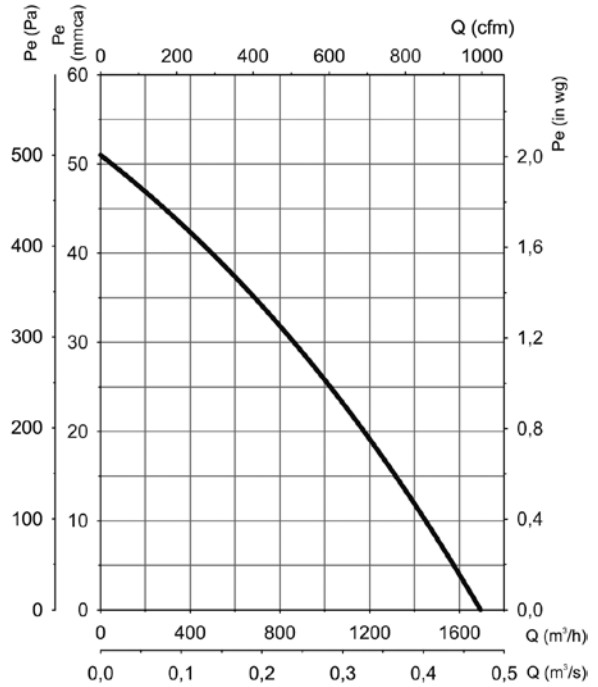

RIRS 2000HE / RIRS 3000HE / RIRS 4000HE

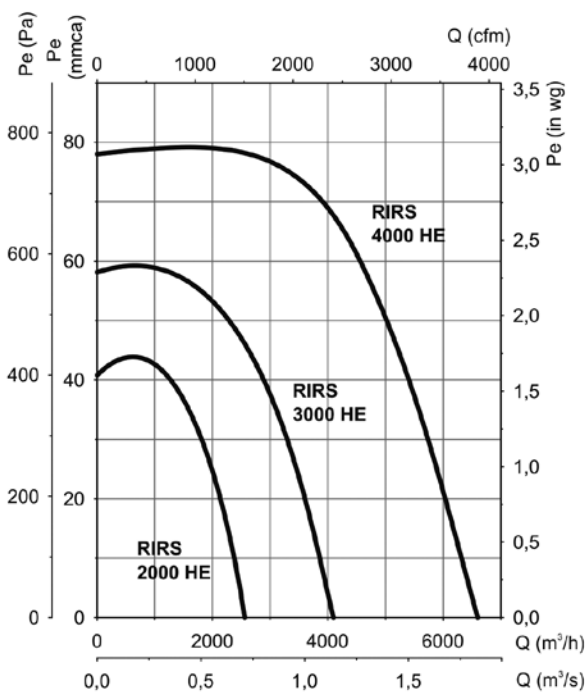

RIRS 2000HW / RIRS 3000HW / RIRS 4000HW

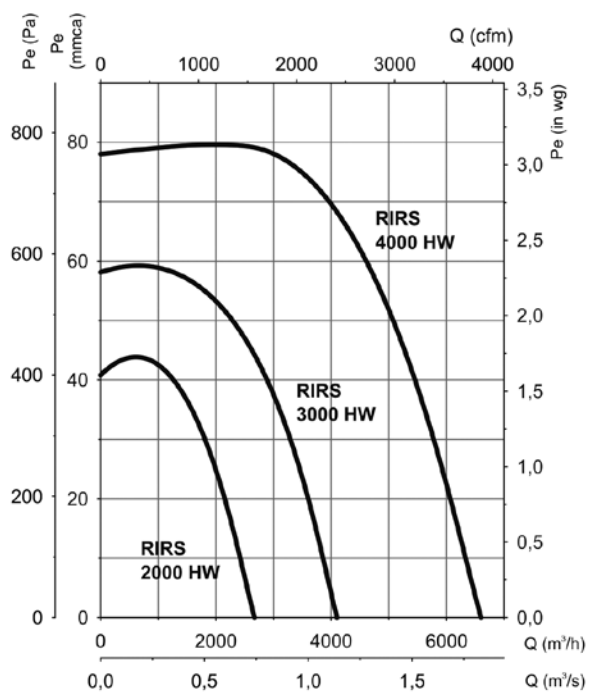

Accessories

See accessories section



SV/FILTER

Low noise in-line duct fans with different stages of filtration.



Features:

- Acoustic casing covered with sound absorbing material.
- Standard aspiration and impulsion joints to aid in duct installation.
- G4 + F6, F6 + F8 and F7 + F9 filters according to model
- Easy access inspection and cleaning cover

Construction:

- Galvanized sheet steel casing
- Backward-curved turbine, except models 125 and 150, which have a multi-blade impeller. Supplied with four supporting feet, to facilitate assembly.
- Large access doors to facilitate maintenance and cleaning.

Motor:

- Class F motors with external rotor, ball bearings, IP54 protection, and built-in thermal protector
- 230V single-phase. -50/60Hz. Adjustable
- Max. temperature of air for transport +50°C

Finish:

- Anticorrosive finish in polyester resin, polymerised at 190°C, after alkaline degreasing and phosphate-free pre-treatment.



Order code

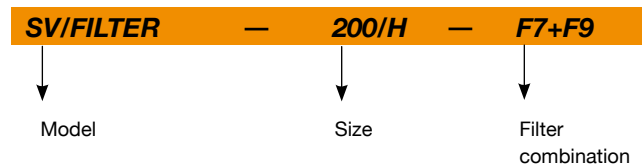

Technical characteristics

Model	Speed (r/min)	Maximum admissible current (A) 230V	Power installed (kW)	Airflow Maximum (m³/h)			No. Pre-filters	No. Filters	Filter Dimensions (mm)		Weight (Kg)
				(G4+F6) filters	(F6+F8) filters	(F7+F9) filters			(G4) filters	(F) filters	
SV/FILTER-125/H	2220	0.65	0.08	300	255	240	1	1	282x194x48	282x194x98	9.1
SV/FILTER-150/H	2200	1.25	0.17	445	385	360	1	1	334x216x48	334x216x98	12.3
SV/FILTER-200/H	1240	0.85	0.12	515	520	390	1	1	389x248x48	389x248x98	15.1
SV/FILTER-250/H	2380	0.95	0.14	660	560	525	1	1	414x267x48	414x267x98	17.8
SV/FILTER-315/H	1330	0.75	0.12	1035	850	790	1	1	513x344x48	513x344x98	26.4
SV/FILTER-350/H	1280	0.95	0.14	1550	1270	1180	1	1	602x385x48	602x385x98	36.3
SV/FILTER-400/H	1330	1.80	0.30	2050	1720	1600	1	1	660x405x48	660x405x98	46.4

Dimensions in mm

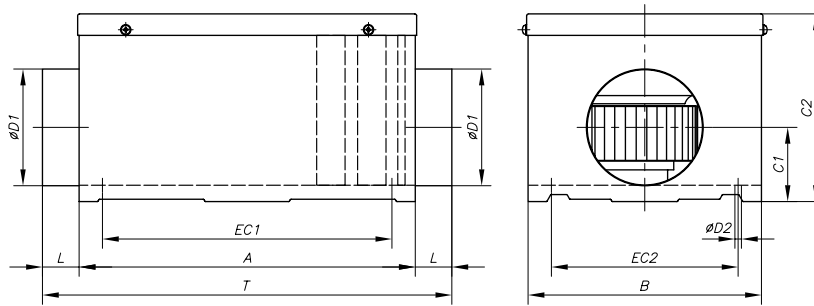

Model	A	B	C1	C2	Ø D1	L	Ø D2	EC1	EC2	T
SV/FILTER-125/H 657	290	80	222	125	36,5	36,5	7	607	240	730
SV/FILTER-150/H 700	340	92	244	150	36,5	36,5	7	650	290	773
SV/FILTER-200/H 775	395	117	273	200	36	36	7	725	345	847
SV/FILTER-250/H 775	395	140	293	250	50	50	7	725	345	875
SV/FILTER-315/H 860	520	175	371	315	48	48	8,5	809	469	956
SV/FILTER-350/H 960	610	200	410	355	48	48	8,5	909	564	1056
SV/FILTER-400/H1035	670	219	455	400	38	38	8,5	984	624	1111

Characteristic curves

Equipment curve according to built-in filters **1** G4+F6 **2** F6+F8 **3** F7+F9

Static pressure

Dynamic pressure

Absorbed power

SV/FILTER125/H

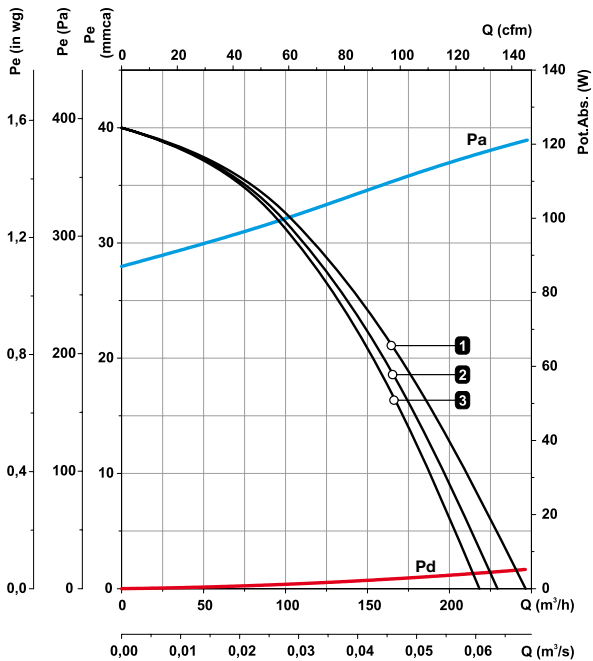

SV/FILTER150/H

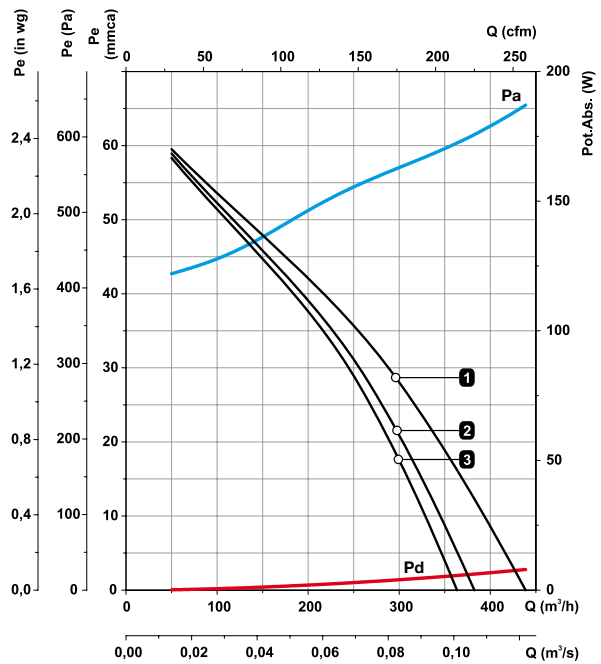

Characteristic curves

Equipment curve according to built-in filters **1** G4+F6 **2** F6+F8 **3** F7+F9

Static pressure

Dynamic pressure

Absorbed power

SV/FILTER200/H

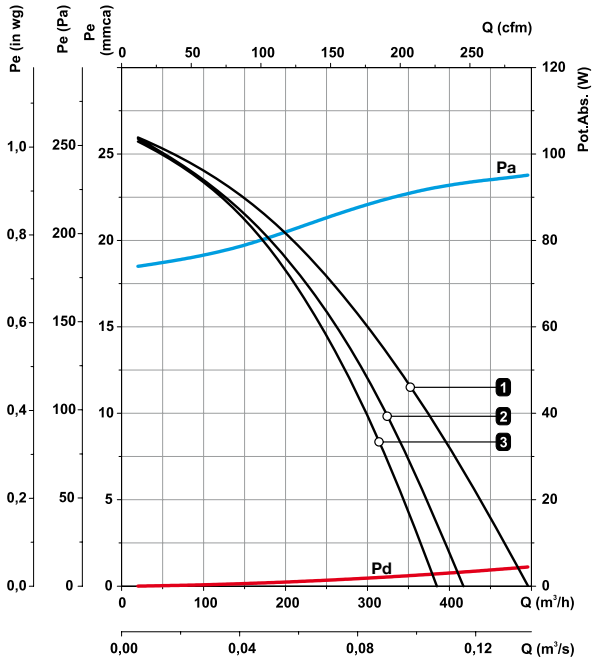

SV/FILTER250/H

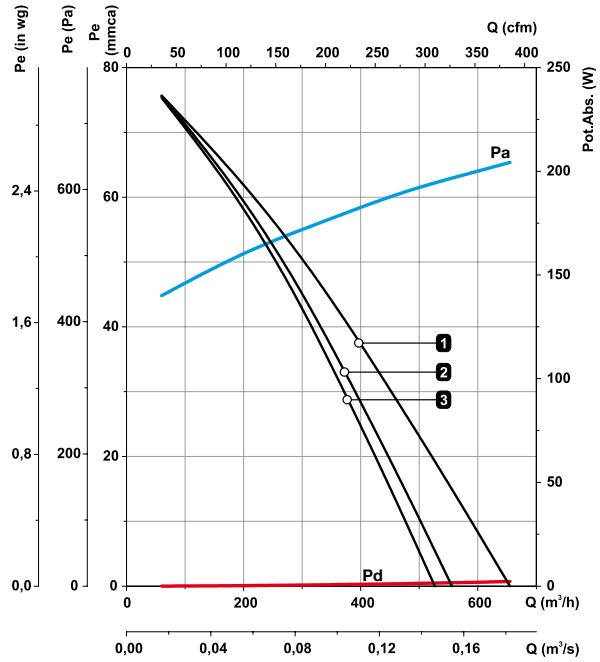

SV/FILTER315/H

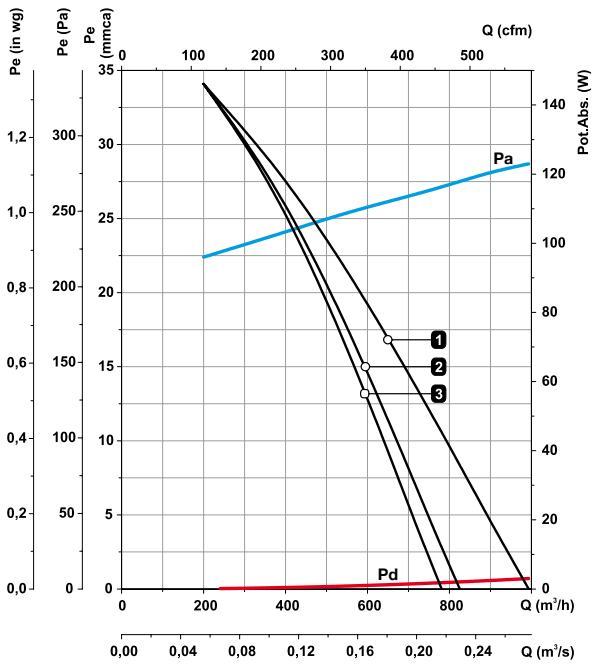

SV/FILTER350/H

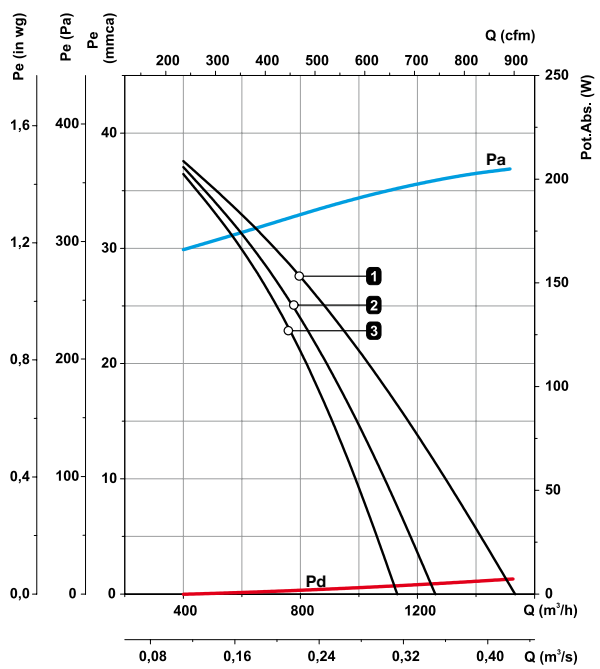

Characteristic curves

Equipment curve according to built-in filters **1** G4+F6 **2** F6+F8 **3** F7+F9

Static pressure

Dynamic pressure

Absorbed power

SV/FILTER400/H

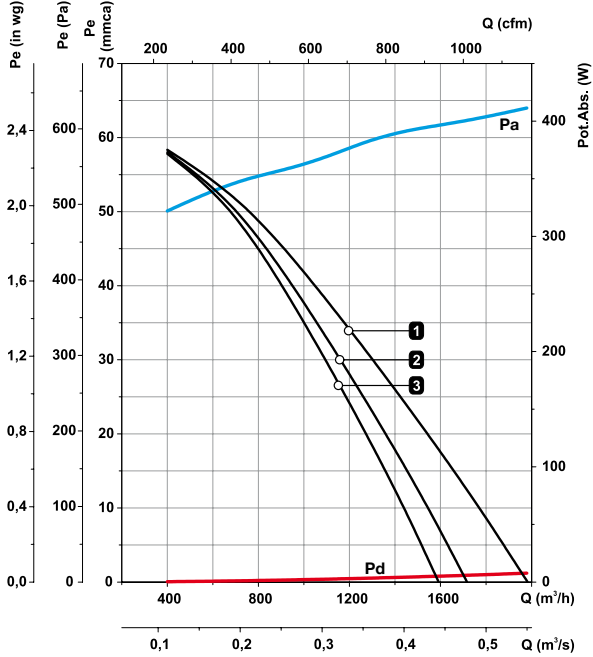

Accessories

See accessories section



FILTERS



CJFILTER



PRESOSTATO



SI-PRESIÓN



PRESSURE PROBE



INT



VIS



TEJ

UFR

Soundproofed filtration units with sandwich panel, equipped with high-performance reaction turbine fans and different stages of filtration according to model.



- F6 + F8**
- F7 + F9**
- G4 + F6**

Features:

- Soundproofed structure
- Direct operation
- Impulsion of air, configurable by 4 laterals
- F6 + F8, F7 + F9 and G4 + F6 filters according to model selected
- Possibility of pre-filter plus two stages of filtration
- Easy access inspection and cleaning cover
- Pressure inlets for filter control
- Pressure probe for filter control

sheet steel

- Built-in general bed
- Easy access inspection and cleaning covers

Motor:

- Class F motors, with bearings, IP55 protection.
- Three-phase 230/400V.-50Hz. (up to 5.5CV.) and 400/690V.-50Hz. (power over 5.5CV.)
- Temperature of the air to be displaced -20°C.+60°C.

Construction:

- Galvanised sheet steel structure with soundproofing.
- High-performance impeller with backward-curved blades made from

Finish:

- Anticorrosive galvanized sheet steel



Order code

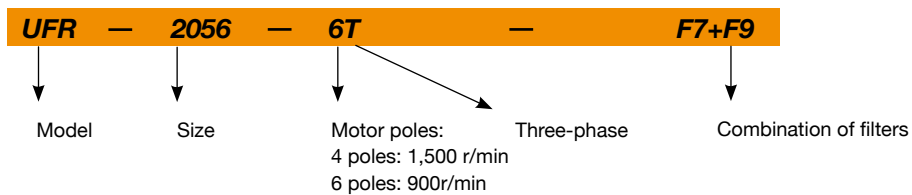

Technical characteristics

Model	Speed (r/min)	Maximum admissible current (A)			Power installed (kW)	Maximum Airflow (m³/h) (F6+F8) filters	Maximum Airflow (m³/h) (F7+F9) filters	Maximum Airflow (m³/h) (G4+F6) filters	No. Pre-filters		Number of filters		Weight (Kg)
		230V	400V	690V					Whole*	Medium*	Whole*	Medium*	
UFR-1240-4T	1430	3.34	1.93		0.75	3,245	3,185	3,005	1	0	1	0	107.5
UFR-1850-4T	1420	5.97	3.45		1.50	4,705	4,620	4,350	1	0	1	0	110
UFR-2056-4T	1430	8.38	4.84		2.20	7,680	7,580	7,235	1	2	1	2	168.5
UFR-2056-6T	935	3.77	2.18		0.75	5,325	5,250	5,010	1	2	1	2	163
UFR-2263-4T	1460		11.03	6.37	5.50	11,995	11,680	11,375	1	2	1	2	221.5
UFR-2263-6T	950	5.23	3.02		1.10	7,200	7,100	7,000	1	2	1	2	177.5
UFR-2071-4T	1460		20.64	11.92	11.00	15,045	14,535	14,060	1	2	1	2	265
UFR-2071-6T-3	940	9.28	5.36		2.20	9,175	8,990	8,810	1	2	1	2	195
UFR-2071-6T-5.5	970	16.35	9.44		4.00	10,130	9,770	9,440	1	2	1	2	241.5
UFR-2880-6T	970	16.35	9.44		4.00	11,500	11,165	10,845	1	2	1	2	242

* Pre-filter dimensions: Full: 585x585x48. Half: 290x585x48

* Filter dimensions: Full: 593x593x292. Half: 288x593x292

Dimensions in mm

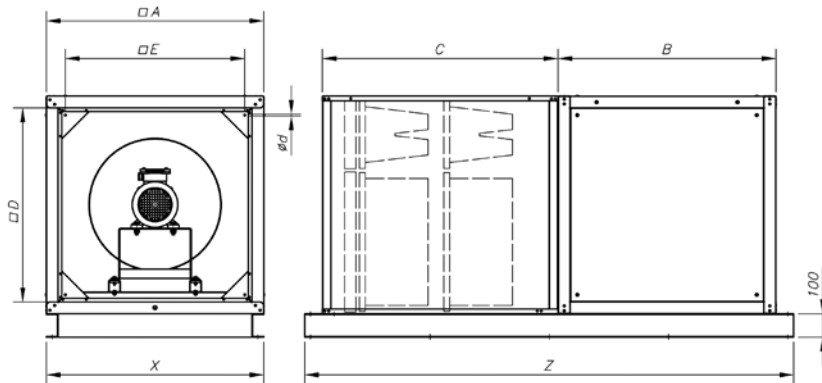

Model	A	B	C	D	E	Ø d	X	Z
UFR-1240-4T	800	800	950	700	640	M6	800	1906
UFR-1850-4T	800	800	950	700	640	M6	800	1906
UFR-2056-4T	925	925	1000	823	763	M6	925	2081
UFR-2056-6T	925	925	1000	823	763	M6	925	2081
UFR-2263-4T	1000	1000	1000	960	838	M6	1000	2156
UFR-2263-6T	925	925	1000	960	763	M6	925	2081
UFR-2071-4T	1060	1060	1000	960	900	M6	1060	2216
UFR-2071-6T	1000	1000	1000	960	838	M6	1000	2156
UFR-2071-6T-5,5	1060	1060	1000	960	900	M6	1060	2216
UFR-2880-6T	1060	1060	1000	960	900	M6	1060	2216

Characteristic curves

Equipment curve according to built-in filters **1** F6+F8 **2** F7+F9 **3** G4+F6

Static pressure

Dynamic pressure

Absorbed power

UFR-1240-4T

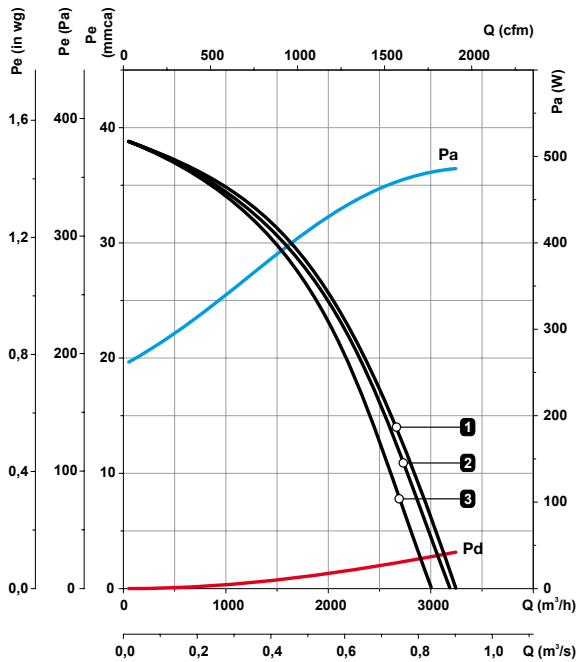

UFR-1850-4T

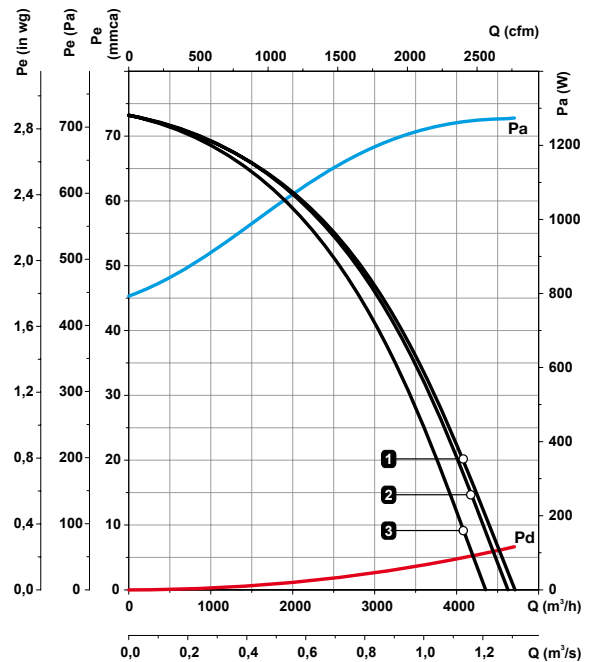

Characteristic curves

Equipment curve according to built-in filters **1** F6+F8 **2** F7+F9 **3** G4+F6

Static pressure

Dynamic pressure

Absorbed power

UFR-2056-4T

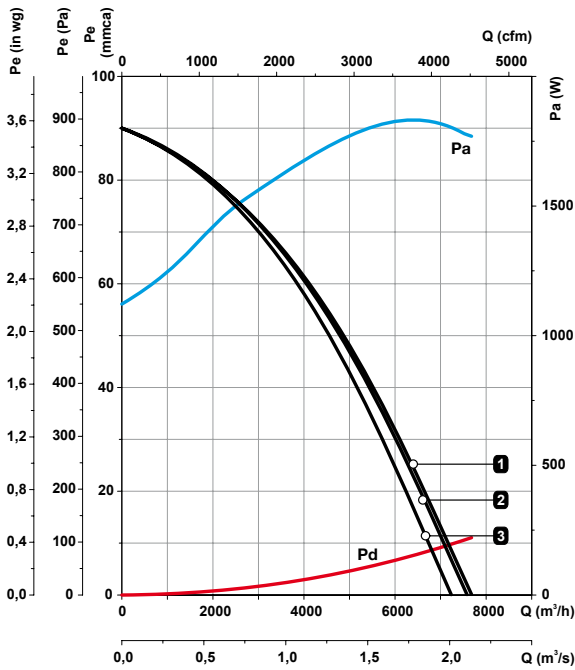

UFR-2056-6T

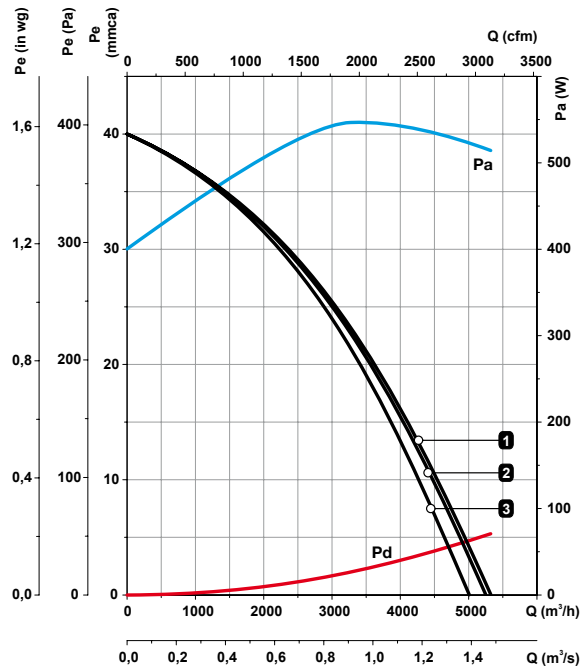

UFR-2263-4T

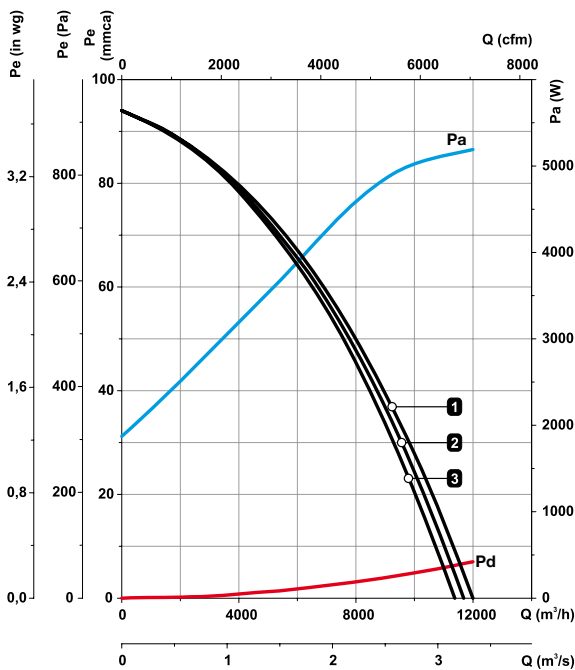

UFR-2263-6T

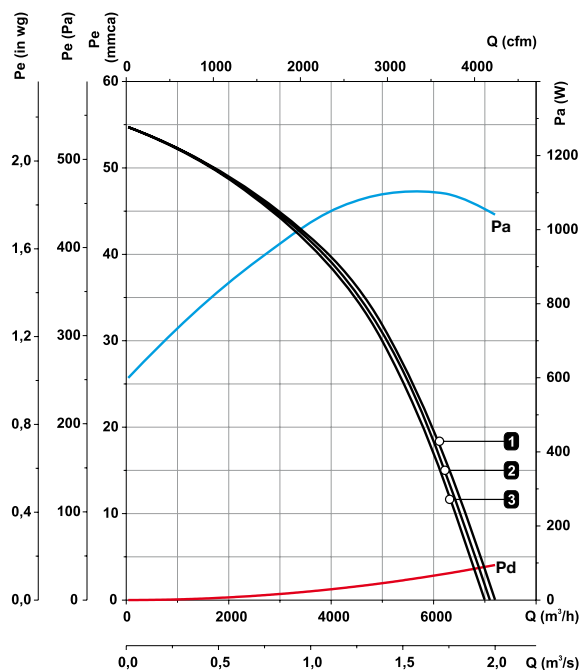

Accessories

See accessories section



FILTERS



CJFILTER



PRESOSTATO



SI-PRESIÓN



CONSTANT FLOW KIT



PRESSURE PROBE



INT



VIS

Characteristic curves

Equipment curve according to built-in filters **1** F6+F8 **2** F7+F9 **3** G4+F6

Static pressure

Dynamic pressure

Absorbed power

UFR-2071-4T

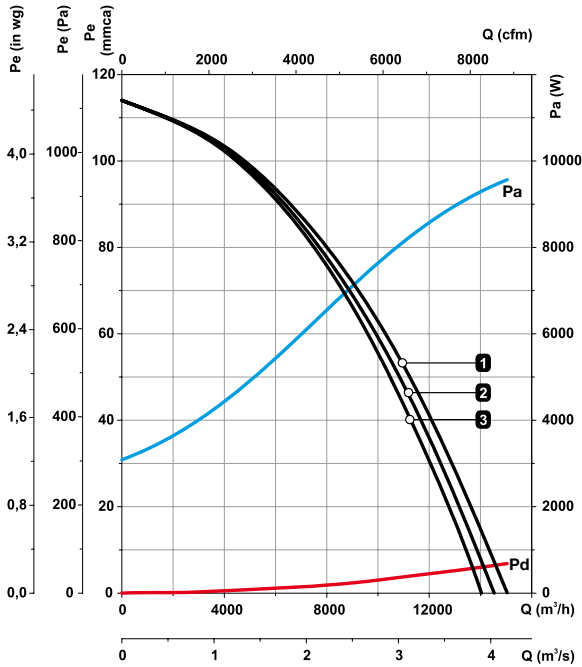

UFR-2071-6T-3

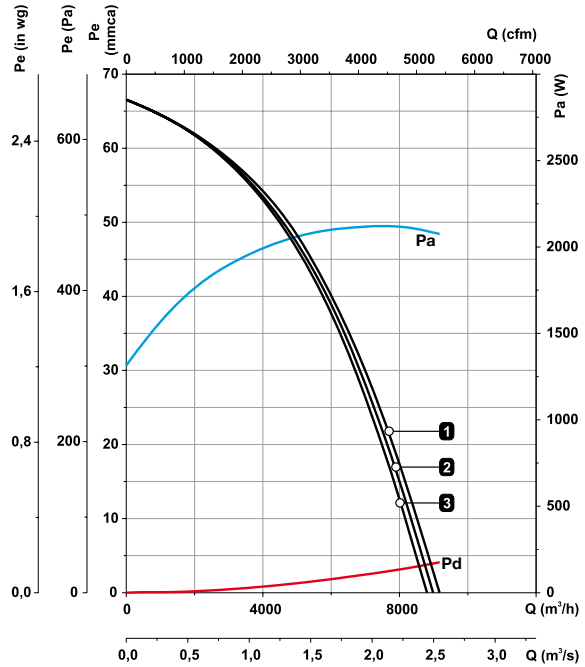

UFR-2071-6T-5,5

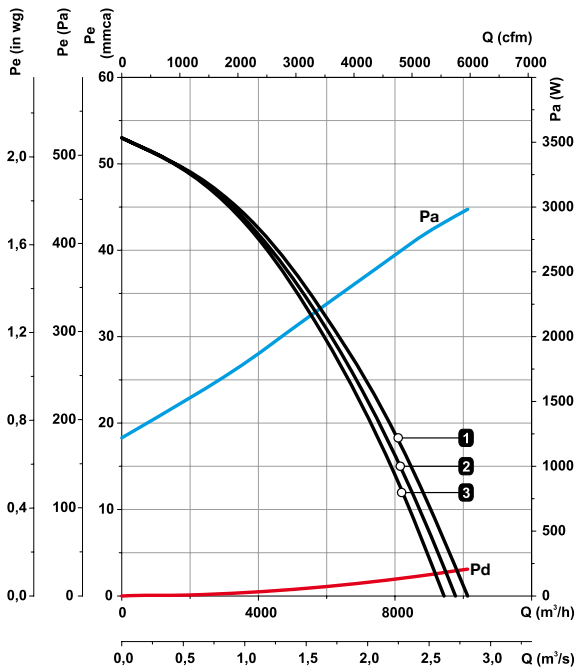

UFR-2880-6T

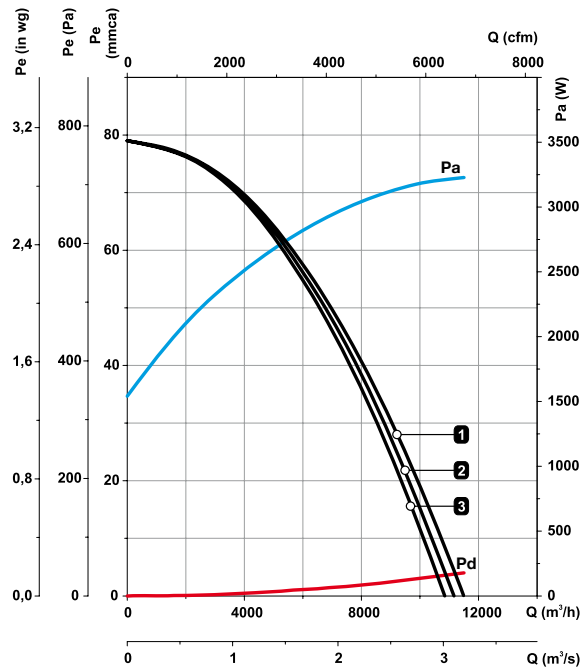

Accessories

See accessories section



TEJ



GENERAL
BEDPLATE



SILENT-
BLOCKS

UFX

Soundproofed filtration units equipped with double inlets and different stages of filtration according to model.



Features:

- Soundproofed structure
- Belt-driven
- F6 + F8, F7 + F9 and G4 + F6 filters according to model selected
- Possibility of pre-filter plus two stages of filtration
- Easy access inspection and cleaning cover
- Pressure inlets for filter control
- Built-in pressure probe

Construction:

- Galvanised sheet steel structure with soundproofing.
- Impeller with forward-facing blades made from galvanised sheet steel
- Stuffing-box for cable inlet

- Built-in general bed
- Easy access inspection and cleaning covers

Motor:

- Class F motors, with bearings, IP55 protection.
- Three-phase 230/400V.-50Hz. (up to 5.5CV) and 400/690V.-50Hz. (power over 5.5CV)
- Temperature of the air to be displaced -20°C.+60°C.

Finish:

- Anticorrosive galvanized sheet steel



Order code

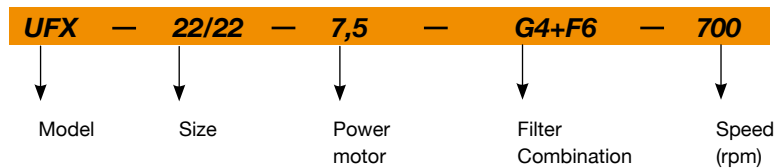

Technical characteristics

Model	Max. Power installed (kW)	Maximum Airflow (m³/h)		Maximum Airflow (m³/h) (G4+F6) filters	No. Pre-filters		Number of filters		Weight (Kg)
		(F6+F8) filters	(F7+F9) filters		Whole*	Medium*	Whole*	Medium*	
UFX-12/12	1.50	5,250	5,100	4,650	1	0	1	0	112
UFX-15/15	3.00	9,050	8,870	8,225	1	2	1	2	148
UFX-18/18	4.00	10,735	10,370	9,320	1	2	1	2	195.5
UFX-20/20	5.50	16,805	16,510	15,575	4	0	4	0	351.5
UFX-22/22	9.20	21,100	20,610	19,110	4	0	4	0	401
UFX-25/25	9.20	26,760	26,190	24,355	4	4	4	4	457
UFX-30/28	15.00	41,060	40,310	37,840	9	0	9	0	575

* Pre-filter dimensions: Full: 585x585x48. Half: 290x585x48

* Filter dimensions: Full: 593x593x292. Half: 288x593x292

Dimensions in mm

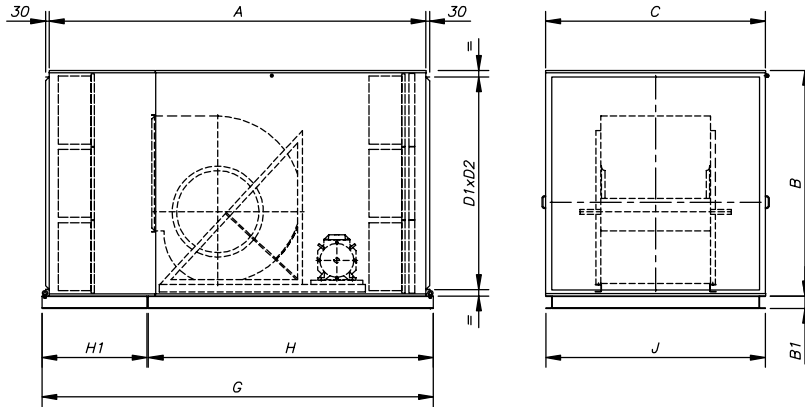

Model	A	B	C	D1	D2	B1	H	H1	G	J
UFX-12/12	1782	650	700	556	606	60	-	-	1902	698
UFX-15/15	2157.5	932.5	888	826	794	80	1610	657.5	2277.5	886
UFX-18/18	2272.5	932.5	888	826	794	80	1725	657.5	2392.5	886
UFX-20/20	2515	1236.5	1192	1123	1095	80	1855	770	2635	1194
UFX-22/22	2630	1236.5	1192	1123	1095	80	1970	770	2750	1194
UFX-25/25	2827	1524.5	1480	1422	1386	100	2083	854	2947	1478
UFX-30/38	3060	1832.5	1786	1727	1690	100	2316	854	3180	1784

Accessories

See accessories section



FILTERS



CJFILTER



PRESOSTATO



SI-PRESIÓN



CONSTANT FLOW KIT



PRESSURE PROBE



INT



VIS



TEJ



GENERAL BEDPLATE



SILENT-BLOCKS

EXAMPLE OF SELECTION OF FILTRATION UNIT UFX

Useful areas according to filters **1** F6+F8 **2** F7+F9 **3** G4+F6
Static pressure Dynamic pressure Sound level dB(A)

Initial data:

- Working flow with clean filters. It is advised to increase the required flow by 10%. In total, there are 4500 m³/h in this example.
- Loss of load from the installation 12 mm.w.c. in this example.
- Desired filter combination. F7+F9 in this example.

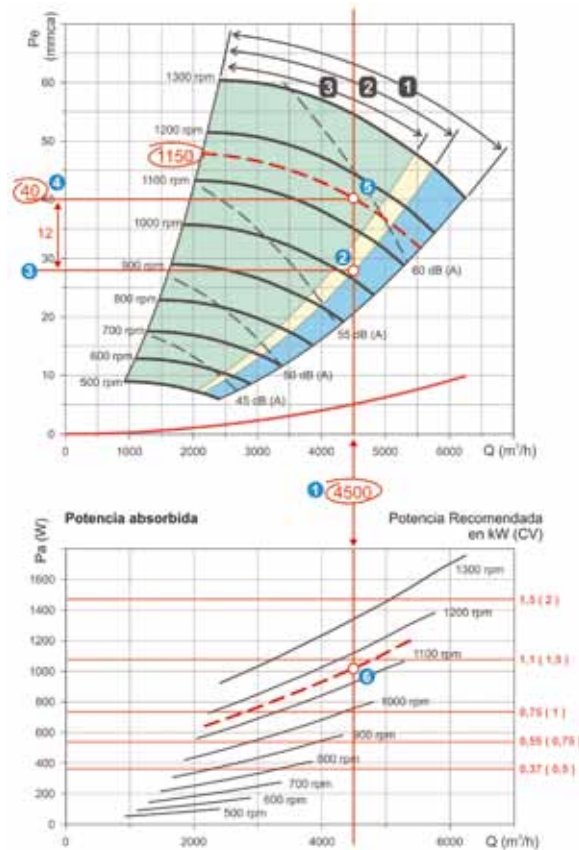

Translation of literals from the graph
 Potencia absorbida: Absorbed power
 Potencia Recomendada en kW (CV): Recommended Power in kW (CV)

Procedure:

- On the flow-pressure graph, trace a vertical line from the point of 4500 m³/h on the flow (1) axis, through the entire graph, to the point of least pressure of the working area of F7 + F9 (2)
- Trace a horizontal line to the pressure scale (3). The value on the Pe scale is the resistance of the 100% clean filters. In this case, 28 mm.w.c.
- Trace a line parallel to the horizontal line, adding the loss of load 12 mm.w.c. of the installation (4).
- Point (5) is the service point of the equipment, under operating conditions: 4500 m³/h at 40 mm.w.c. It is verified that the service point is within the useful area of F7+F9. If this is not so, another piece of equipment must be found.
- The speed of transmission is determined by the position of the service point, between two curves at a known speed. In this case, the result is 1150 rpm.
- As the filters get dirty, the pressure will increase and the flow will diminish following the curve of 1150 rpm. The dirty filter must be replaced by a clean one when the flow is reduced to below the acceptable level, or the pressure rises above the maximum indicated on the RITE.
- In the graph of absorbed power, it is possible to find the appropriate motor, tracing a curve of 1150 rpm, between the curves drawn. In the intersection with the flow line, the service point is obtained (6)
- The power immediately above the operating point is 1.5 C.V.

Characteristic curves

Useful areas according to filters **1** F6+F8 **2** F7+F9 **3** G4+F6
 Static pressure Dynamic pressure Sound level dB(A)

UFX-12/12

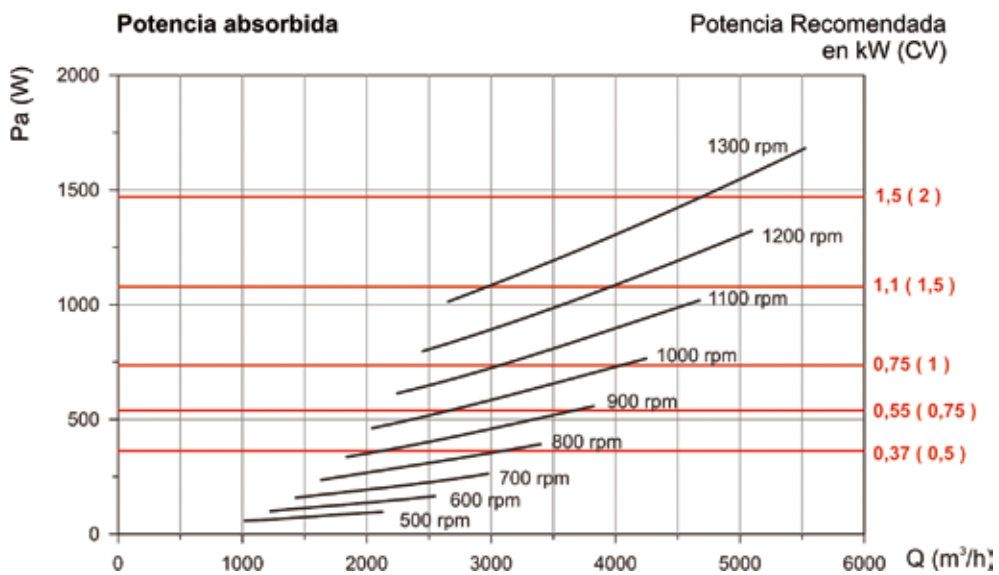
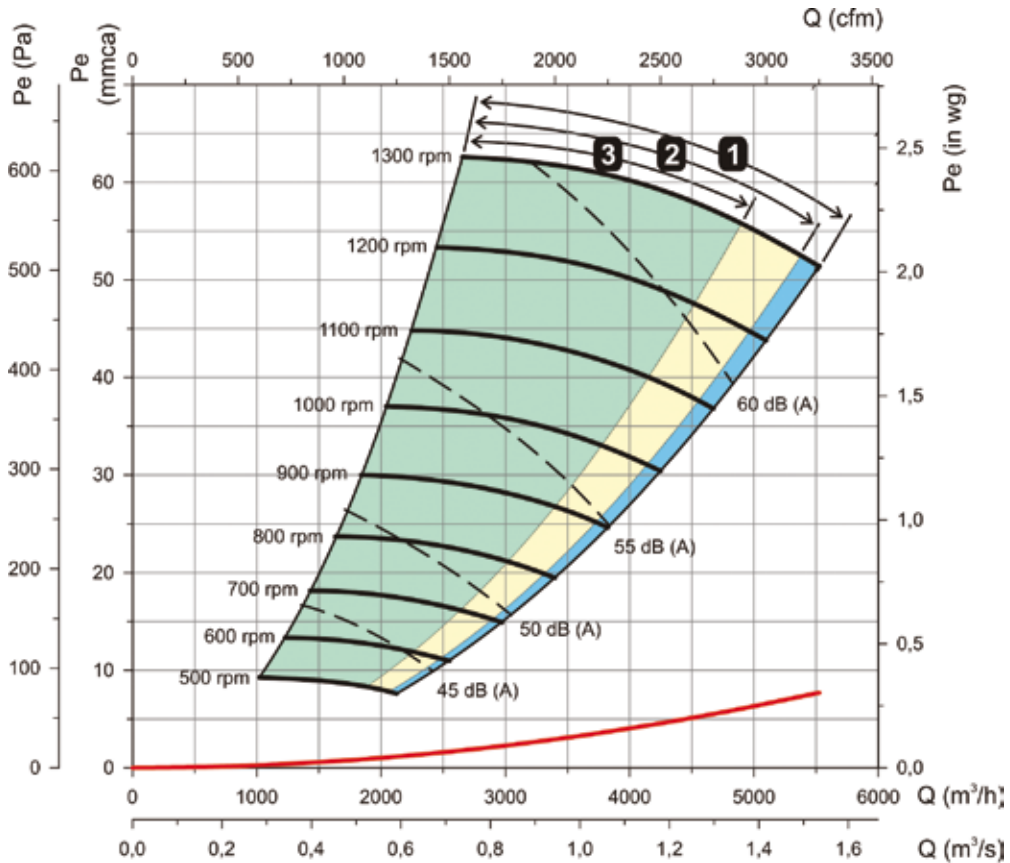

Translation of literals from the graph
 Potencia absorbida: Absorbed power
 Potencia Recomendada en kW (CV): Recommended Power in kW (CV)

Characteristic curves

Useful areas according to filters **1** F6+F8 **2** F7+F9 **3** G4+F6
 Static pressure Dynamic pressure Sound level dB(A)

UFX-15/15

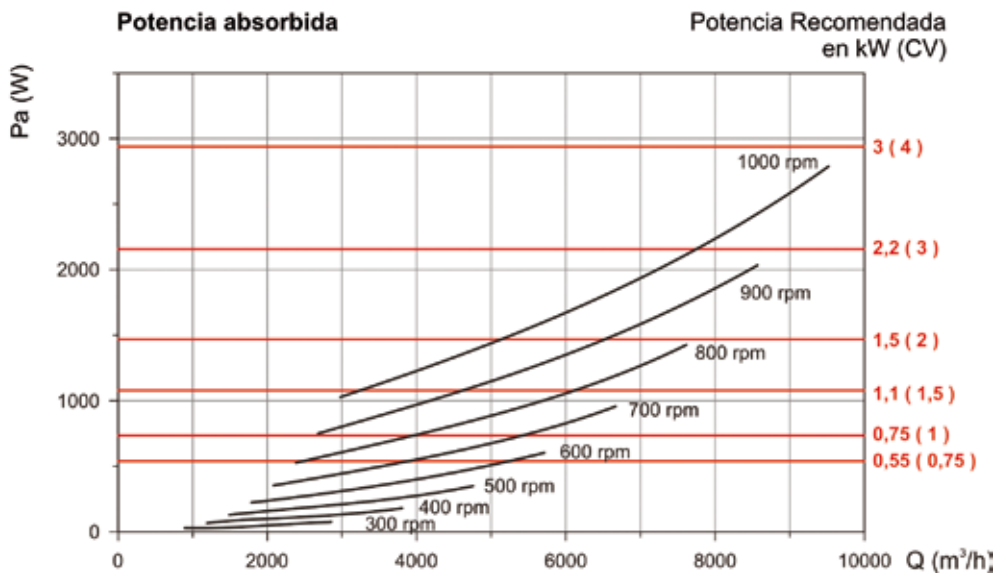
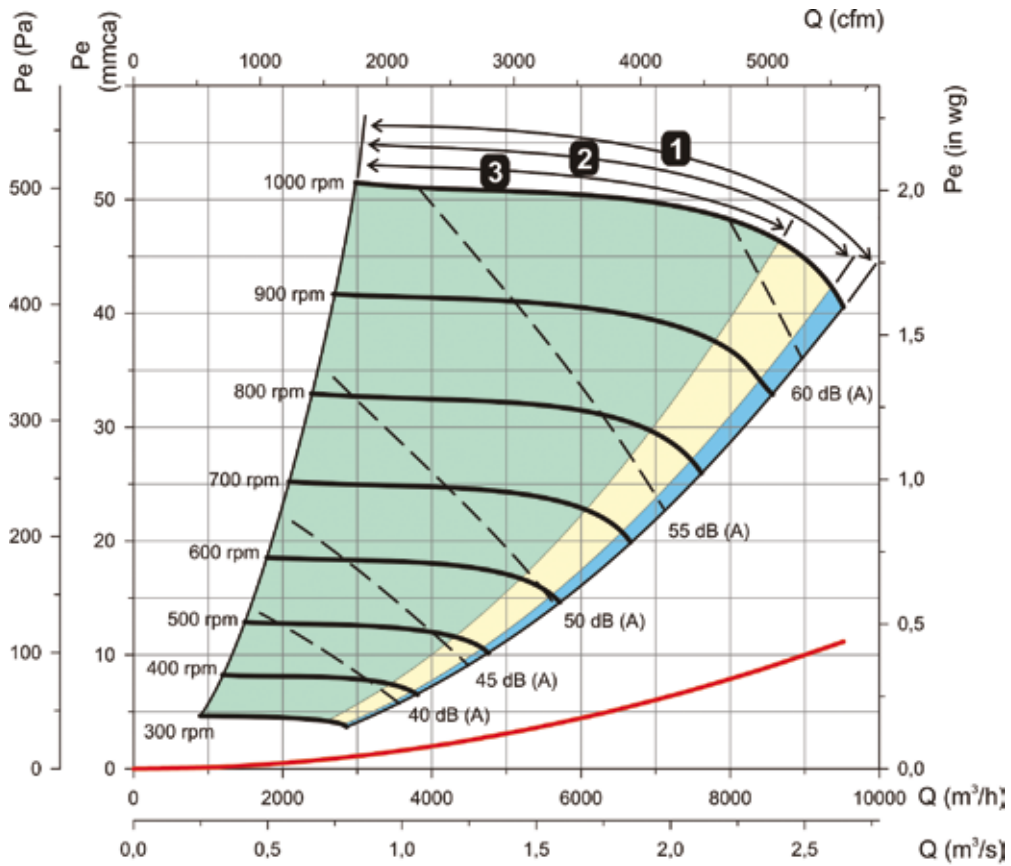

Translation of literals from the graph
 Potencia absorbida: Absorbed power
 Potencia Recomendada en kW (CV): Recommended Power in kW (CV)

Characteristic curves

Useful areas according to filters **1** F6+F8 **2** F7+F9 **3** G4+F6
 Static pressure Dynamic pressure Sound level dB(A)

UFX-18/18

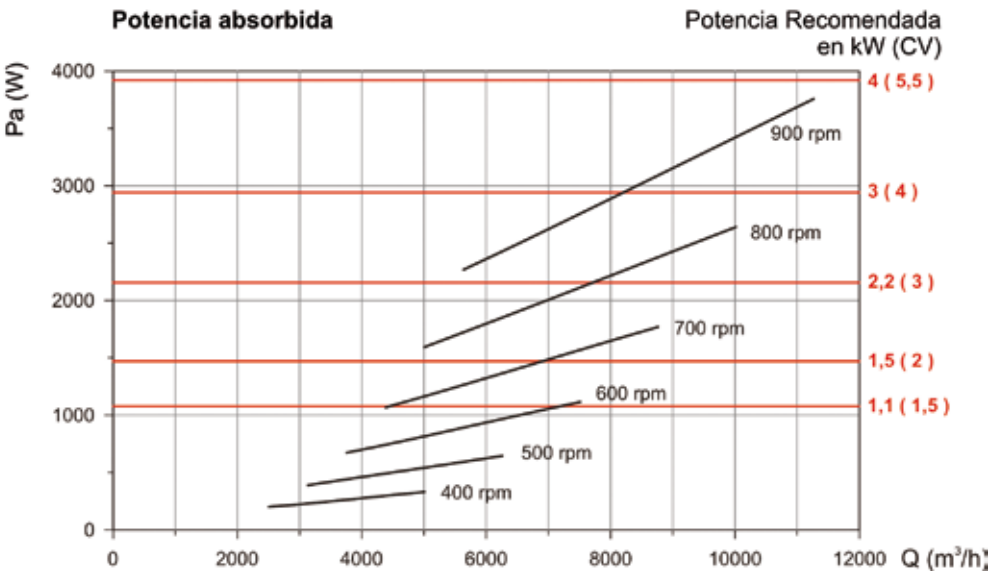
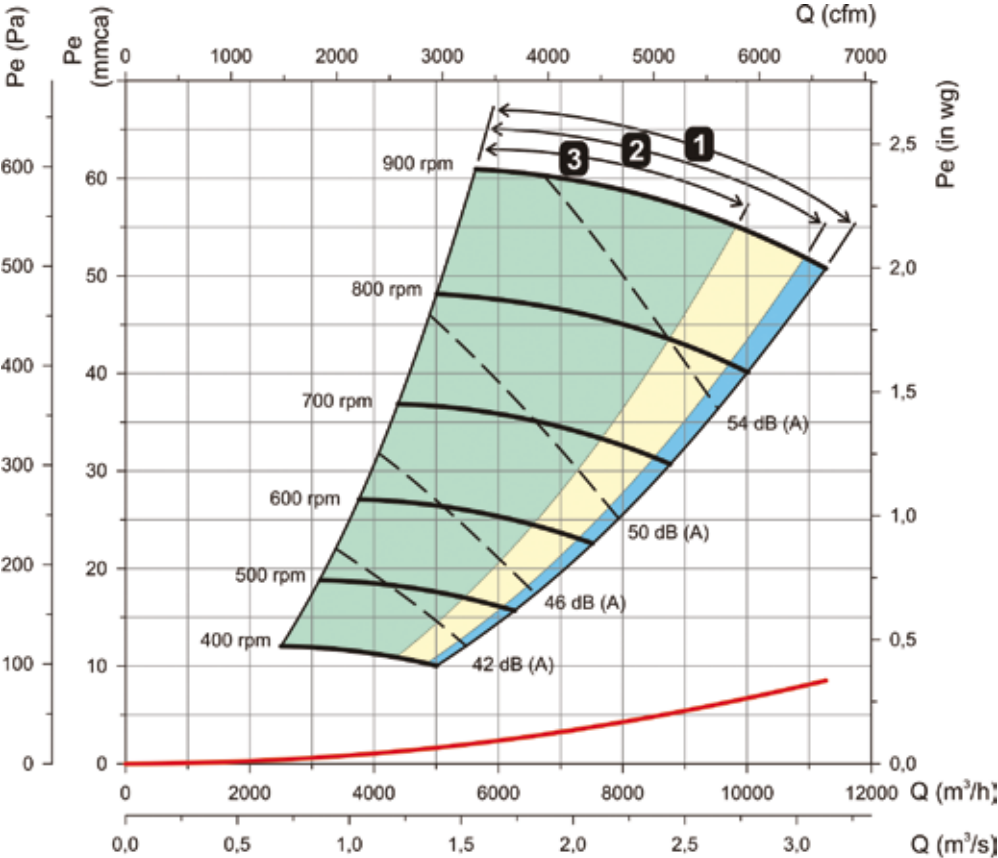

Translation of literals from the graph
 Potencia absorbida: Absorbed power
 Potencia Recomendada en kW (CV): Recommended Power in kW (CV)

Characteristic curves

Useful areas according to filters **1** F6+F8 **2** F7+F9 **3** G4+F6
 Static pressure Dynamic pressure Sound level dB(A)

UFX-20/20

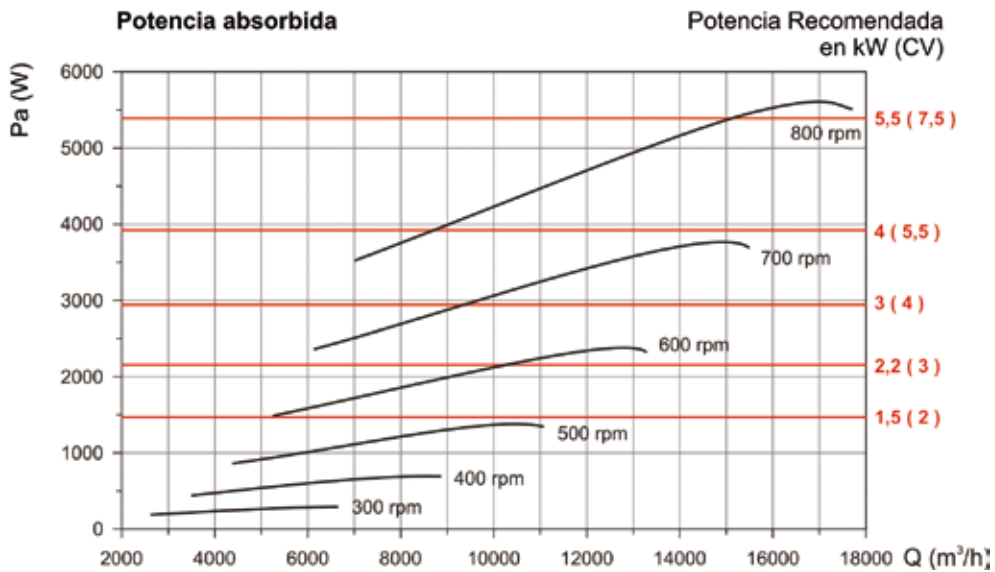
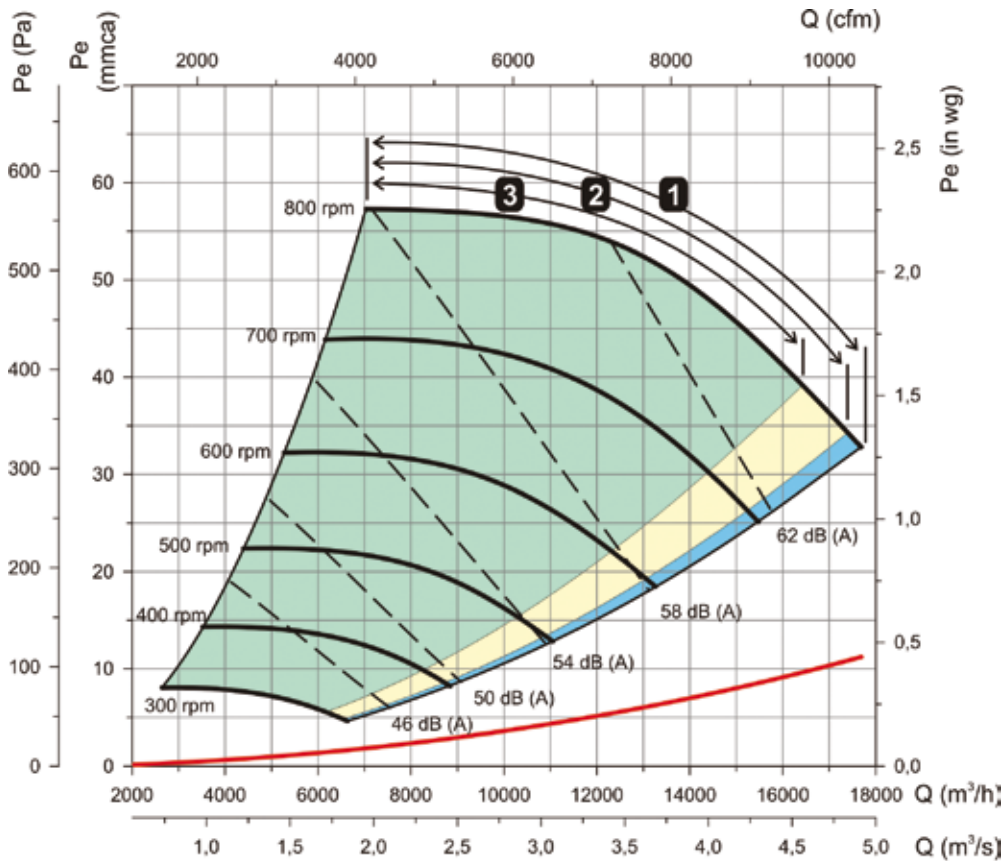

Translation of literals from the graph
 Potencia absorbida: Absorbed power
 Potencia Recomendada en kW (CV): Recommended Power in kW (CV)

Characteristic curves

Useful areas according to filters **1** F6+F8 **2** F7+F9 **3** G4+F6
 Static pressure Dynamic pressure Sound level dB(A)

UFX-22/22

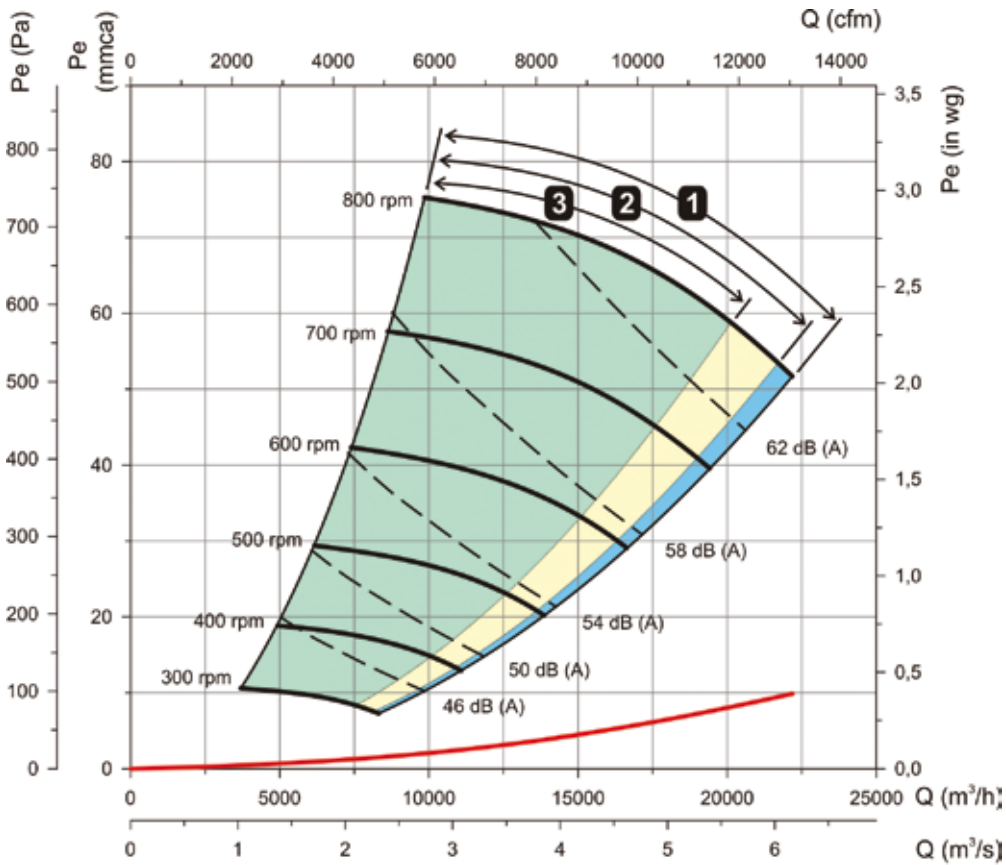

Potencia absorbida

Potencia Recomendada en kW (CV)

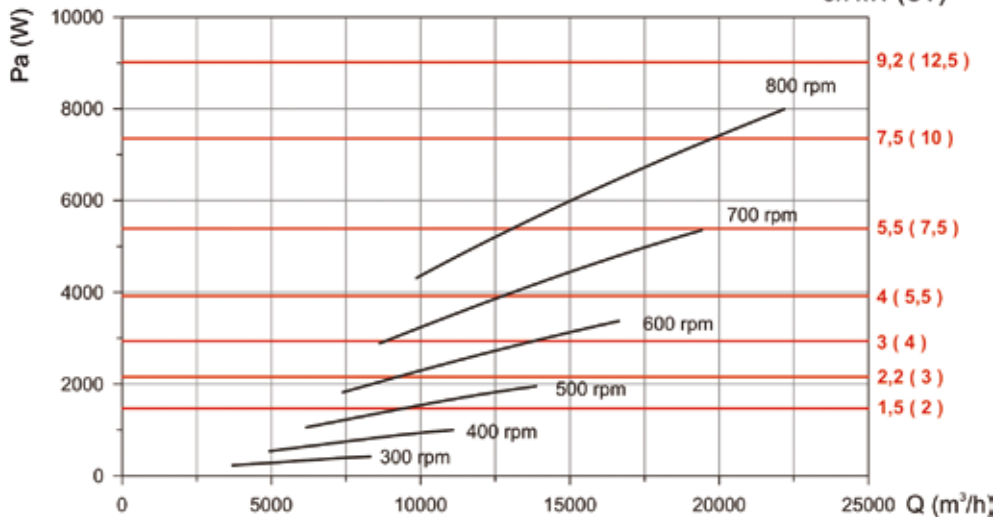

Translation of literals from the graph
 Potencia absorbida: Absorbed power
 Potencia Recomendada en kW (CV): Recommended Power in kW (CV)

Characteristic curves

Useful areas according to filters **1** F6+F8 **2** F7+F9 **3** G4+F6
 Static pressure Dynamic pressure Sound level dB(A)

UFX-25/25

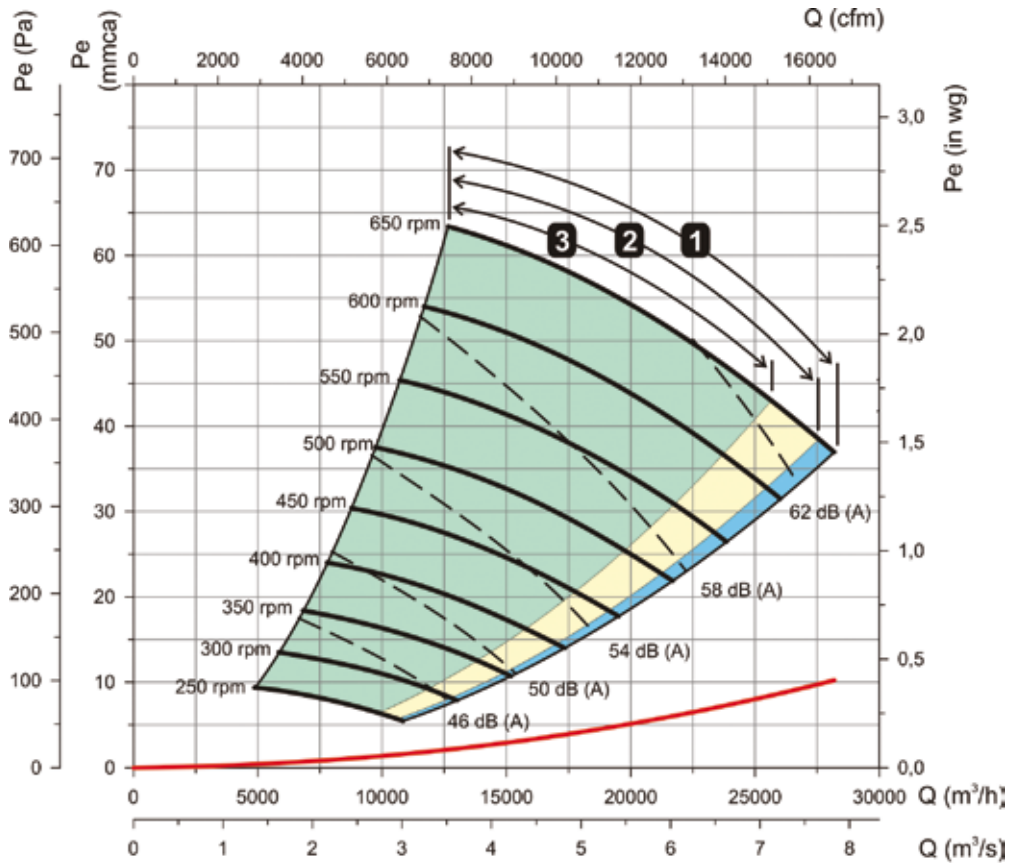

Potencia absorbida

Potencia Recomendada en kW (CV)

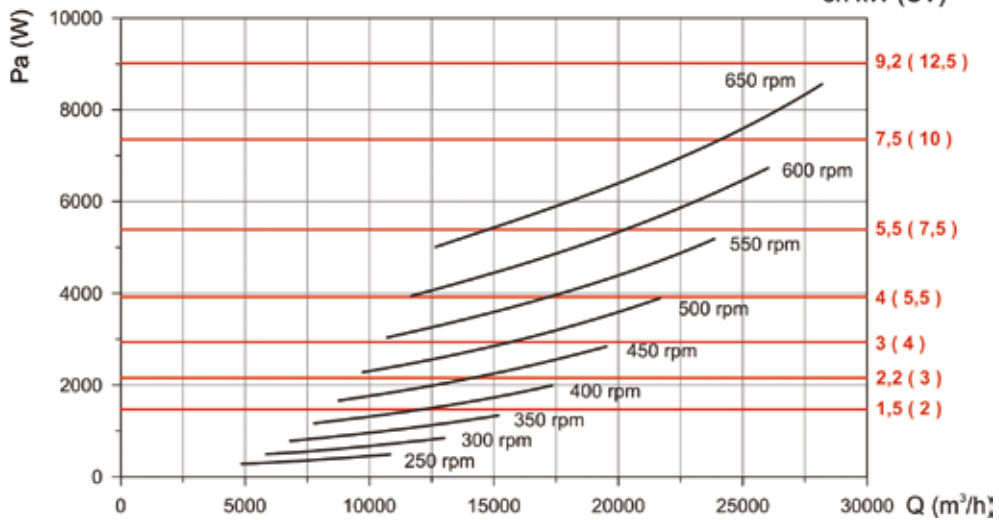

Translation of literals from the graph
 Potencia absorbida: Absorbed power
 Potencia Recomendada en kW (CV): Recommended Power in kW (CV)

Characteristic curves

Useful areas according to filters **1** F6+F8 **2** F7+F9 **3** G4+F6
 Static pressure Dynamic pressure Sound level dB(A)

UFX-30/28

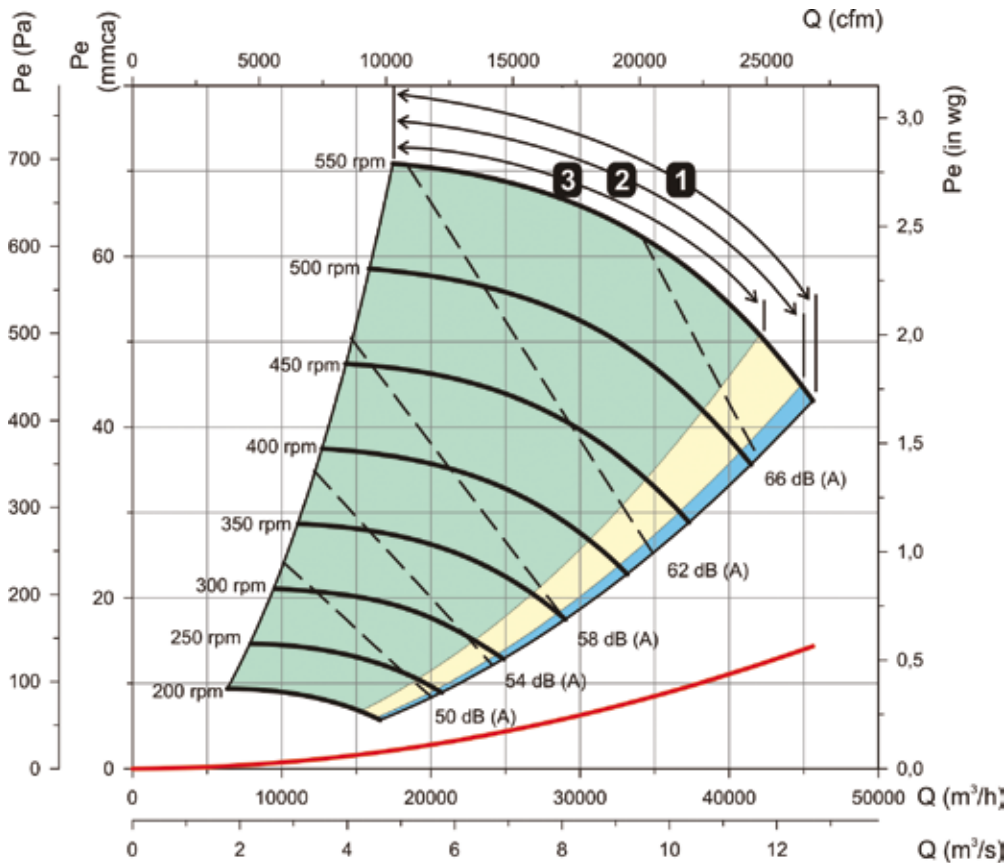

Potencia absorbida

Potencia Recomendada en kW (CV)

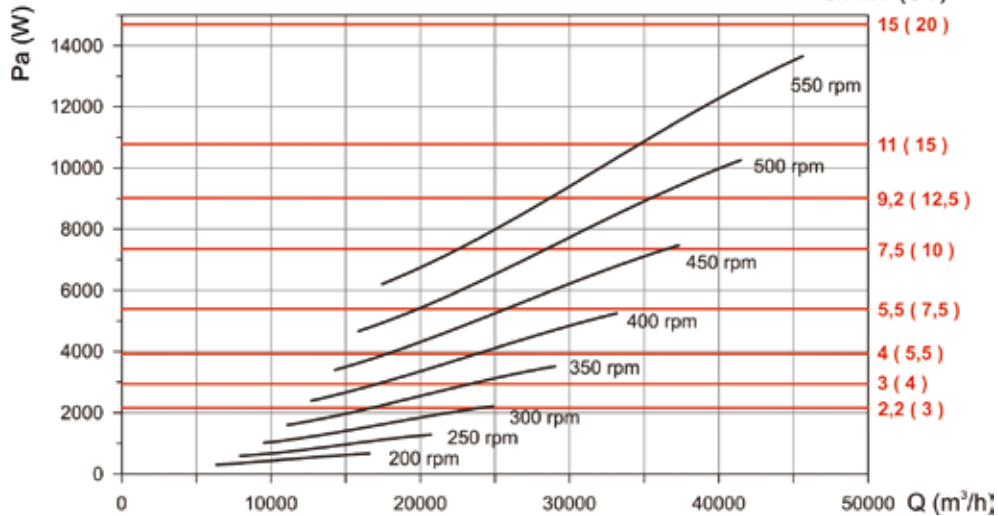

Translation of literals from the graph
 Potencia absorbida: Absorbed power
 Potencia Recomendada en kW (CV): Recommended Power in kW (CV)

UFRX

Soundproofed filtration units equipped with double inlet fans and very robust reaction turbine and different stages of filtration according to model.



Features:

- Belt-driven
- Built-in general bed
- F6 + F8, F7 + F9 and G4 + F6 filters
- Possibility of pre-filter plus three stages of filtration
- Easy access inspection and cleaning covers
- Pressure inlets and pressure probe for filter control

- Easy access inspection and cleaning covers

Motor:

- Class F motors, with bearings, IP55 protection.
- Three-phase 230/400V.-50Hz. (up to 5.5cv) and 400/690V.-50Hz. (power over 5.5CV)
- Temperature of the air to be displaced -20°C.+60°C.

Construction:

- Structure with aluminium profiles
- Soundproofed sandwich panel
- Impeller with backward-curved blades made from sheet steel
- Built-in general bed

Finish:

- Anticorrosive sheet steel pre-lacquered



Order code

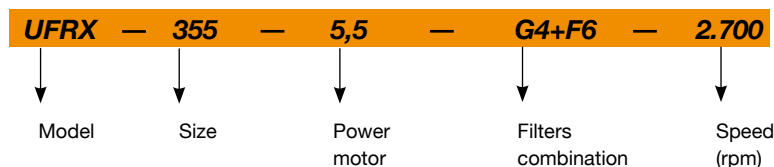

Technical characteristics

Model	Max. Power installed (kW)	Maximum Airflow (m³/h) (F6+F8) filters	Maximum Airflow (m³/h) (F7+F9) filters	Maximum Airflow (m³/h) (G4+F6) filters	No. Pre-filters		Number of filters		Weight (Kg)
					Whole*	Medium*	Whole*	Medium*	
UFRX-315	3.00	8,550	8,075	7,600	1	2	1	2	117
UFRX-355	5.50	12,330	11,645	10,960	4	0	4	0	155.5
UFRX-400	9.20	16,470	15,555	14,640	4	0	4	0	204
UFRX-450	11.00	20,700	19,550	18,400	4	4	4	4	364.5
UFRX-500	15.00	28,800	27,200	25,600	9	0	9	0	415
UFRX-560	18.50	36,360	34,340	32,320	9	0	9	0	478
UFRX-630	18.50	43,000	42,000	41,000	9	0	9	0	594

* Pre-filter dimensions: Full: 585x585x48. Half: 290x585x48
 * Filter dimensions: Full: 593x593x292. Half: 288x593x292

Dimensions in mm

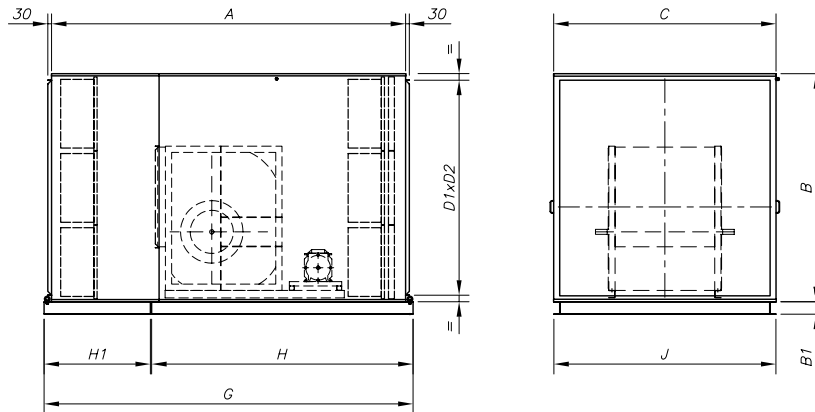

Model	A	B	C	Height D1	Width D2	B1	H	H1	G	J
UFRX-315	1987.5	932.5	888	826	794	80	1440	657.5	2107.5	886
UFRX-355	2401	1236.5	1192	1123	1095	80	1741	770	2521	1194
UFRX-400	2401	1236.5	1192	1123	1095	80	1741	770	2521	1194
UFRX-450	2485	1524.5	1480	1422	1386	100	1741	854	2605	1478
UFRX-500	2622	1832.5	1786	1727	1690	100	1878	854	2742	1784
UFRX-560	2844	1832.5	1786	1727	1690	100	2100	854	2964	1784
UFRX-630	2844	1832.5	1786	1727	1690	100	2100	854	2964	1784

Accessories

See accessories section

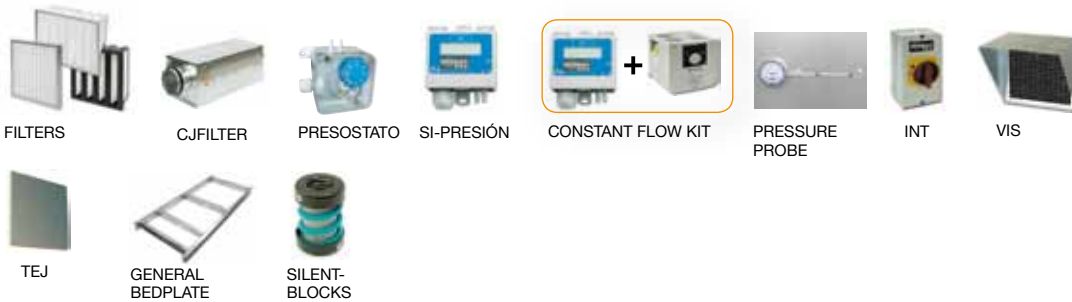

EXAMPLE OF SELECTION OF FILTRATION UNIT UFRX

Useful areas according to filters: **1** F6+F**2** F7+**3** G4+F6
Static pressure Dynamic pressure Sound power dB(A)

Initial data:

- Working flow with clean filters. It is advised to increase the required flow by 10%. In total, there are 7.000 m³/h in this example.
- Loss of load from the installation 72 mm.w.c. in this example.
- Desired combination of filters F6+F8 in this example.

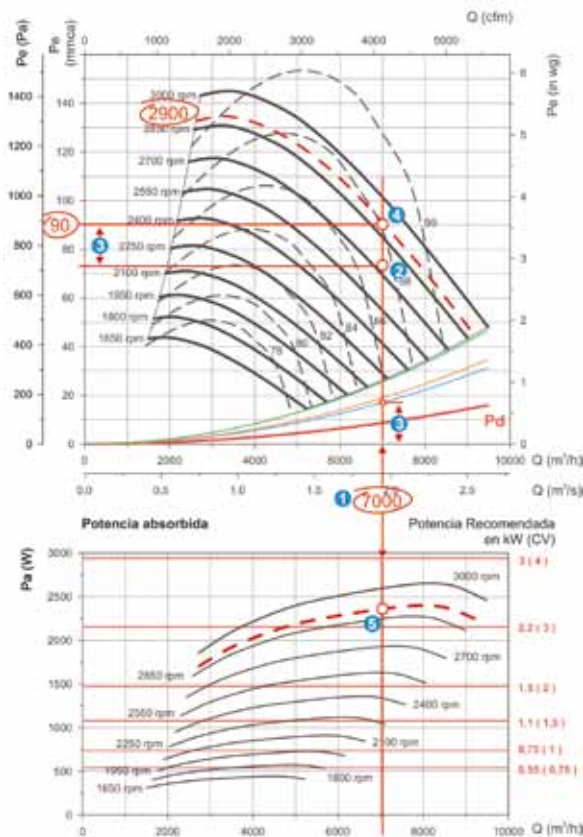

Procedure:

- On the flow-pressure graph, trace a vertical line from the point of 7000 m³/h on the flow (1) axis, through the entire graph, to the working pressure of the installation (2).
- At point (2) add the loss of load from the F6+F8 filters, in this case 18 mm.w.c.(3), obtaining point(4). The loss of load of the 100% clean filters is considered.
- The resulting Point (4) is the service point of the equipment, under operating conditions: 7.000 m³/h at 90 mm.w.c. It is verified that the service point is within the area covered by the curves. If this is not so, another piece of equipment must be found.
- The speed of transmission is determined by the position of the service point, between two curves at a known speed. In this case, the result is 2900 rpm.
- As the filters get dirty, the pressure will increase and the flow will diminish following the curve of 2900 rpm. The dirty filter must be replaced by a clean one when the flow is reduced to below the acceptable level, or the pressure rises above the maximum indicated on the RITE.
- In the graph of absorbed power, it is possible to find the appropriate motor, tracing a curve of 2900 rpm, between the curves drawn. In the intersection with the flow line, the service point is obtained (5). The recommended power is immediately above the operating point, 4 C.V. in the example.

Translation of literals from the graph
 Potencia absorbida: Absorbed power
 Potencia Recomendada en kW (CV): Recommended Power in kW (CV)

Characteristic curves

Useful areas according to filters: **1** F6+F2 **2** F7+3 **3** G4+F6

Static pressure Dynamic pressure Sound power dB(A) - - -

UFRX-315

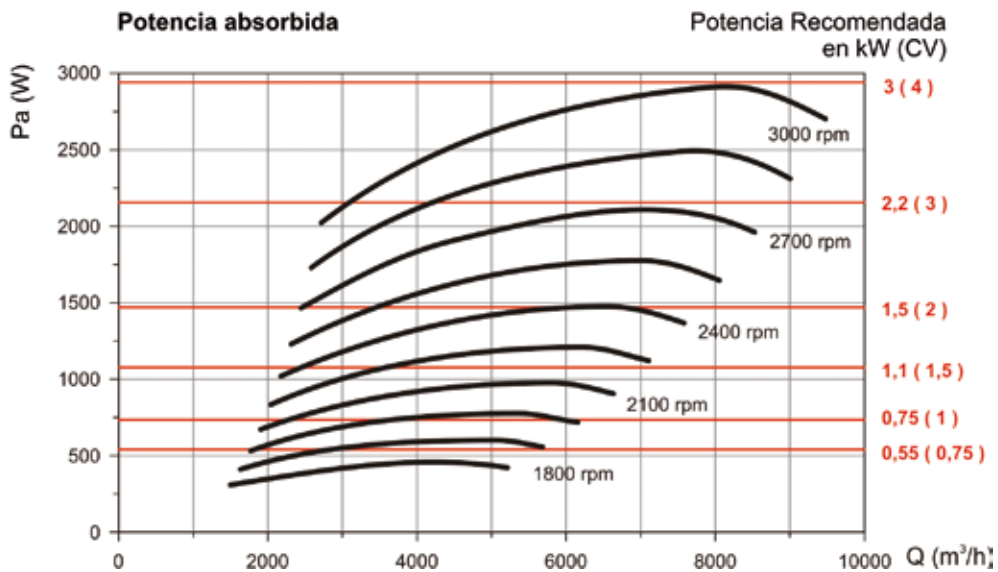
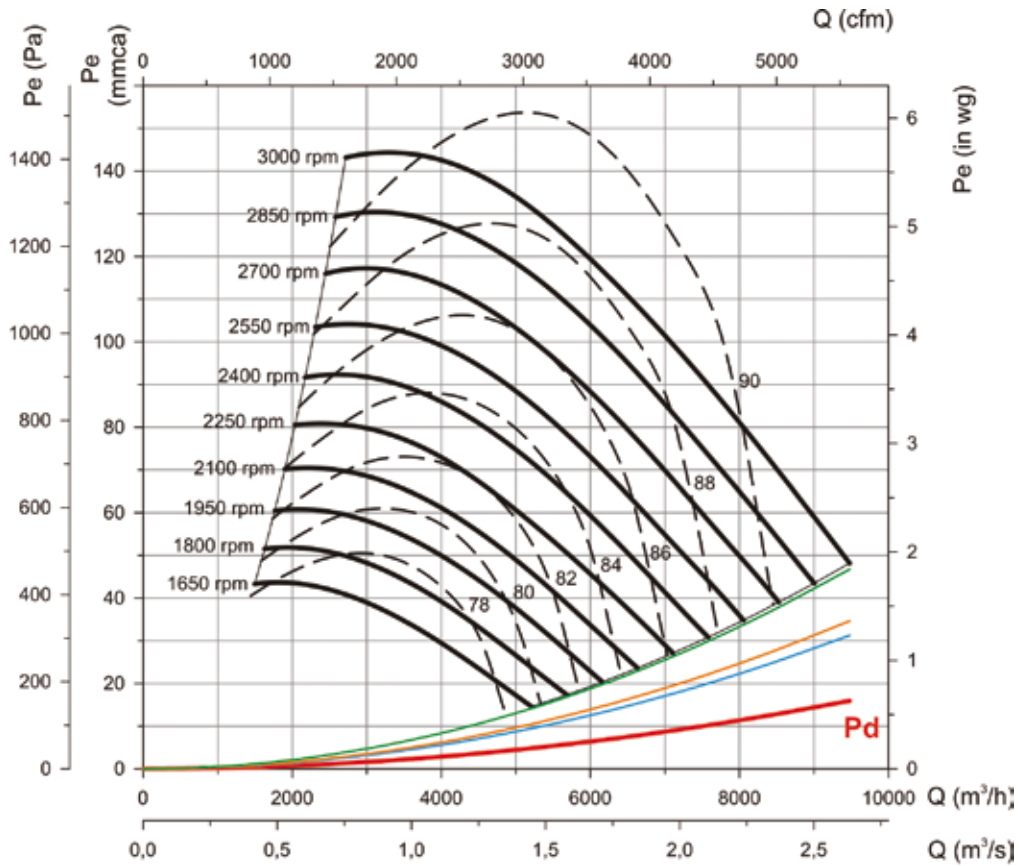

Translation of literals from the graph
 Potencia absorbida: Absorbed power
 Potencia Recomendada en kW (CV): Recommended Power in kW (CV)

Characteristic curves

Useful areas according to filters: **1** F6+F2 **2** F7+3 **3** G4+F6

Static pressure Dynamic pressure Sound power dB(A) - - -

UFRX-355

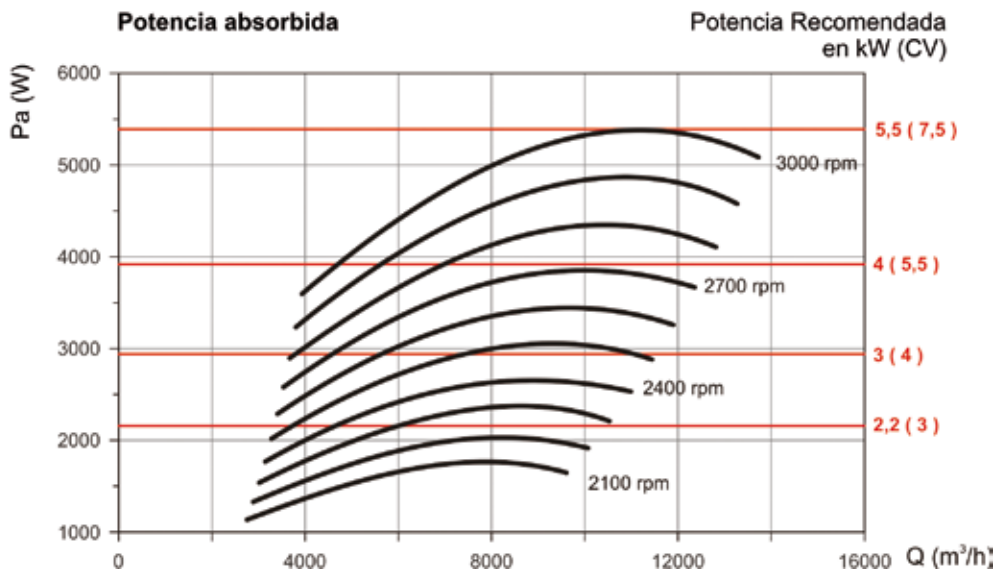
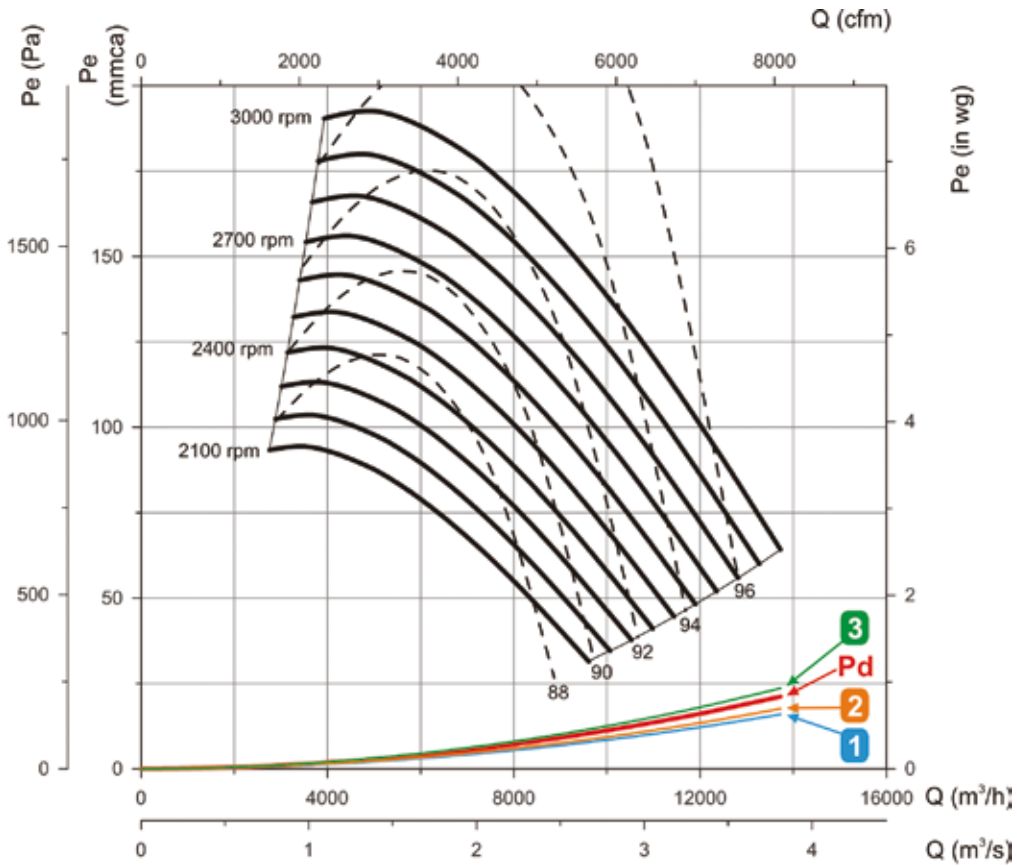

Translation of literals from the graph
 Potencia absorbida: Absorbed power
 Potencia Recomendada en kW (CV): Recommended Power in kW (CV)

Characteristic curves

Useful areas according to filters: **1** F6+F2 **2** F7+3 **3** G4+F6

Static pressure Dynamic pressure Sound power dB(A) - - -

UFRX-400

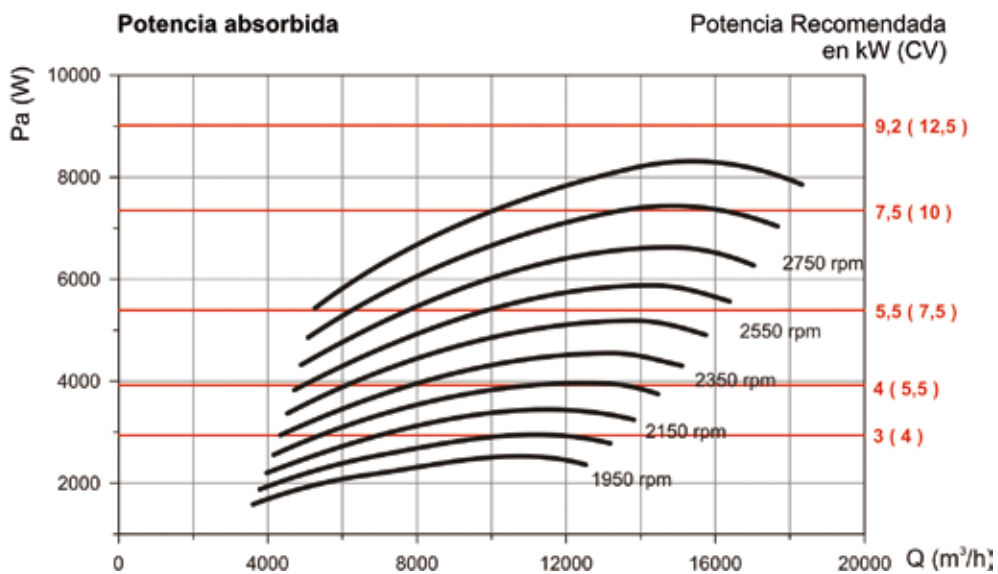
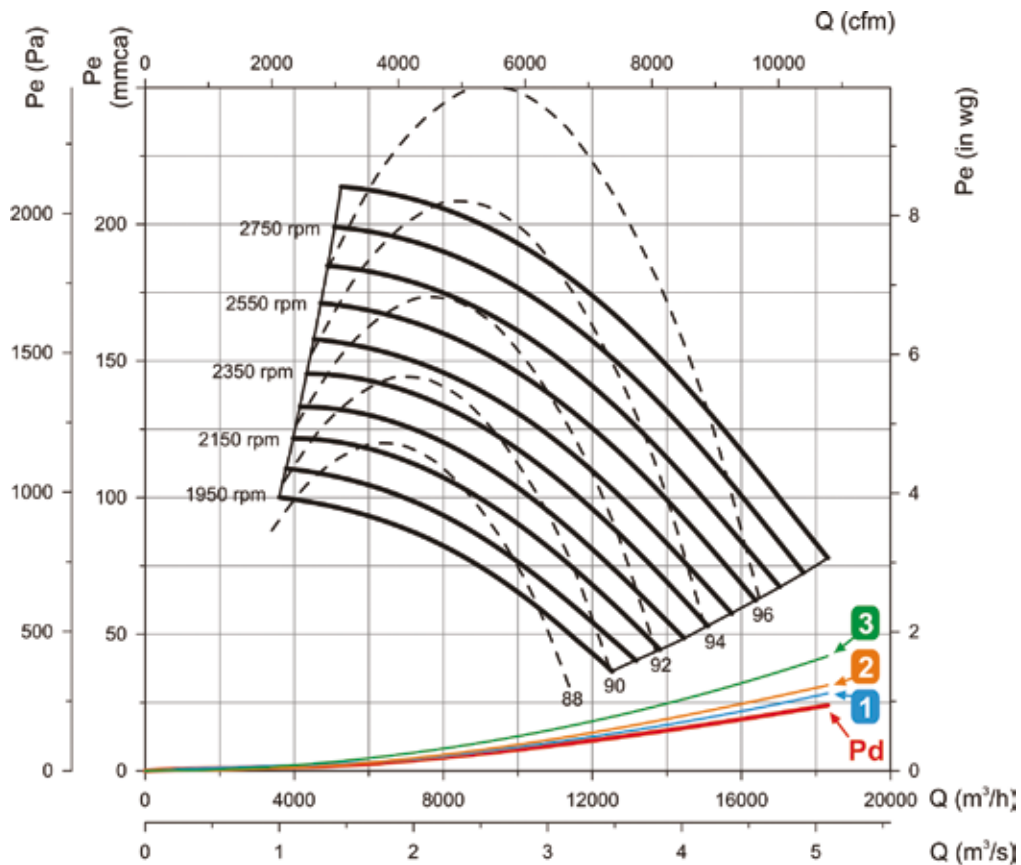

Translation of literals from the graph
 Potencia absorbida: Absorbed power
 Potencia Recomendada en kW (CV): Recommended Power in kW (CV)

Characteristic curves

Useful areas according to filters: **1** F6+F2 **2** F7+3 **3** G4+F6

Static pressure Dynamic pressure Sound power dB(A) - - -

UFRX-450

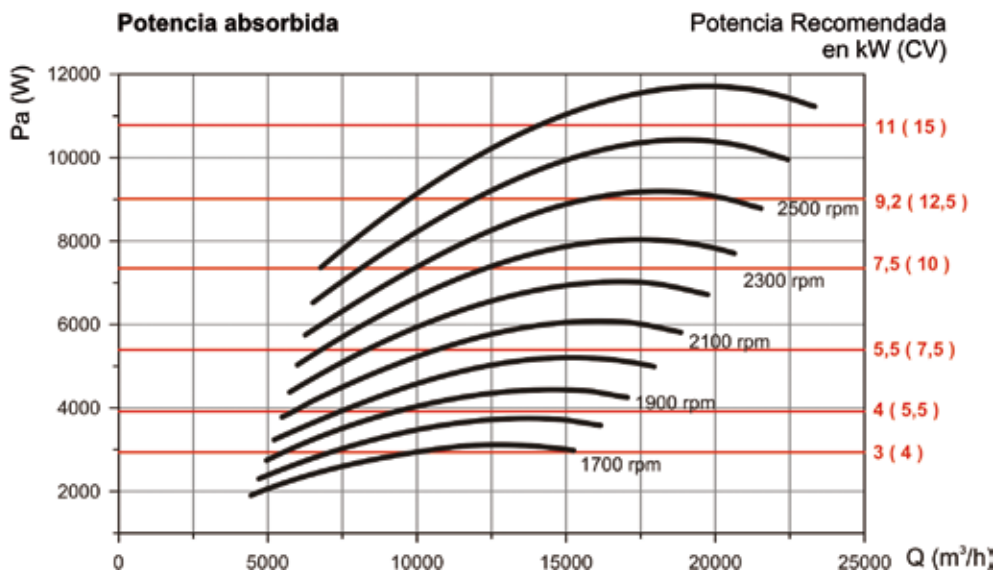
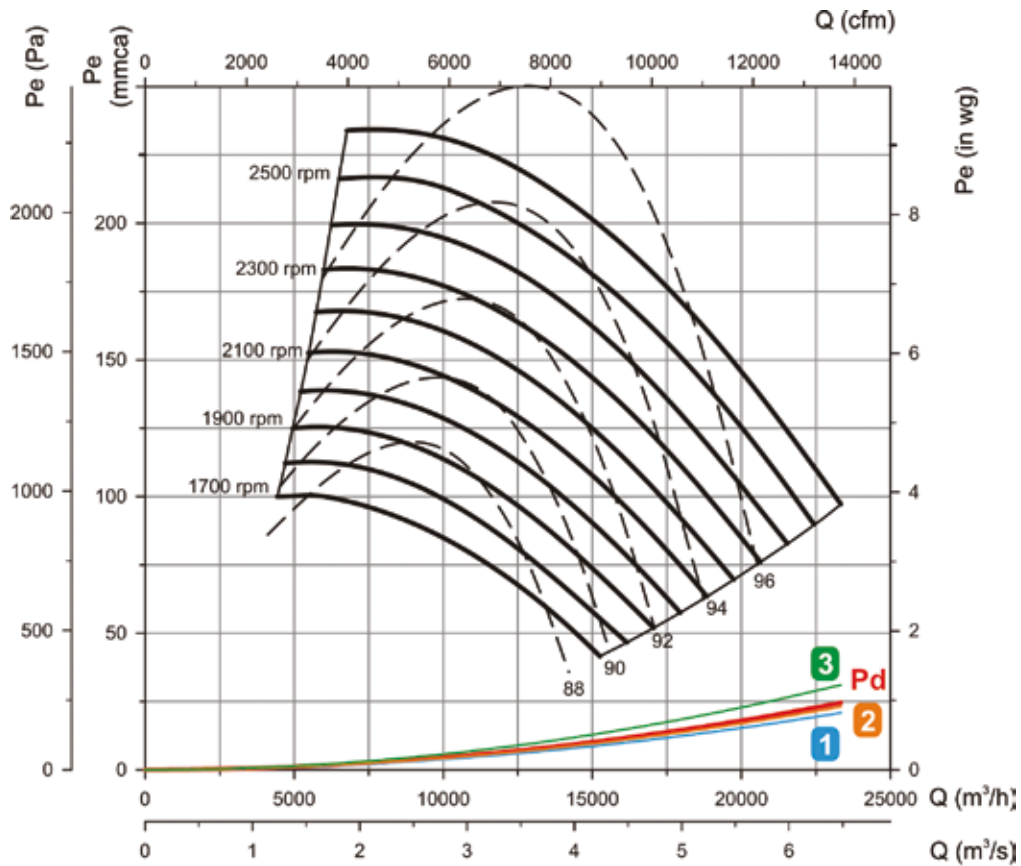

Translation of literals from the graph
 Potencia absorbida: Absorbed power
 Potencia Recomendada en kW (CV): Recommended Power in kW (CV)

Characteristic curves

Useful areas according to filters: **1** F6+F2 **2** F7+3 **3** G4+F6

Static pressure Dynamic pressure Sound power dB(A) - - -

UFRX-500

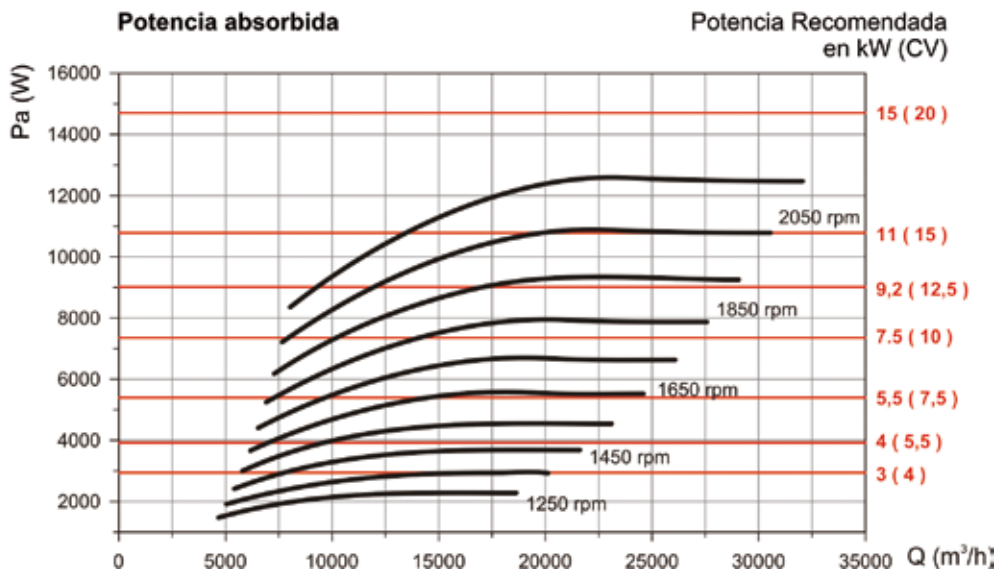
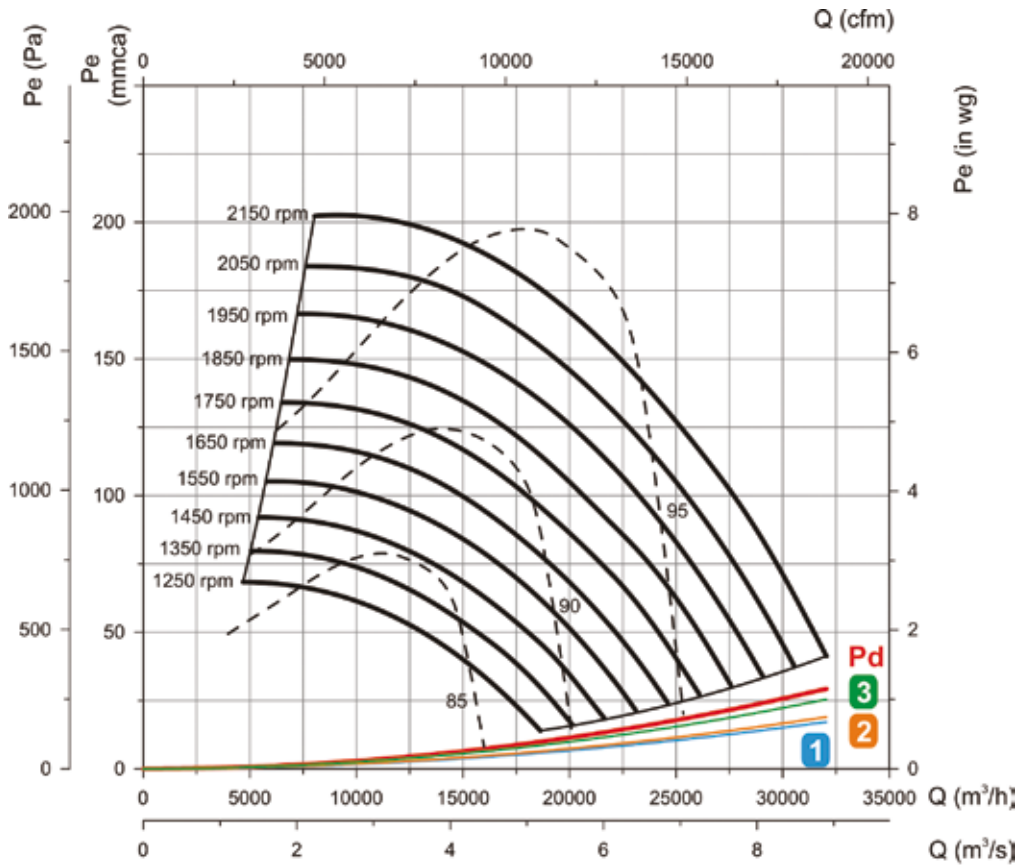

Translation of literals from the graph
 Potencia absorbida: Absorbed power
 Potencia Recomendada en kW (CV): Recommended Power in kW (CV)

Characteristic curves

Useful areas according to filters: **1** F6+F2 **2** F7+3 **3** G4+F6

Static pressure Dynamic pressure Sound power dB(A) - - -

UFRX-560

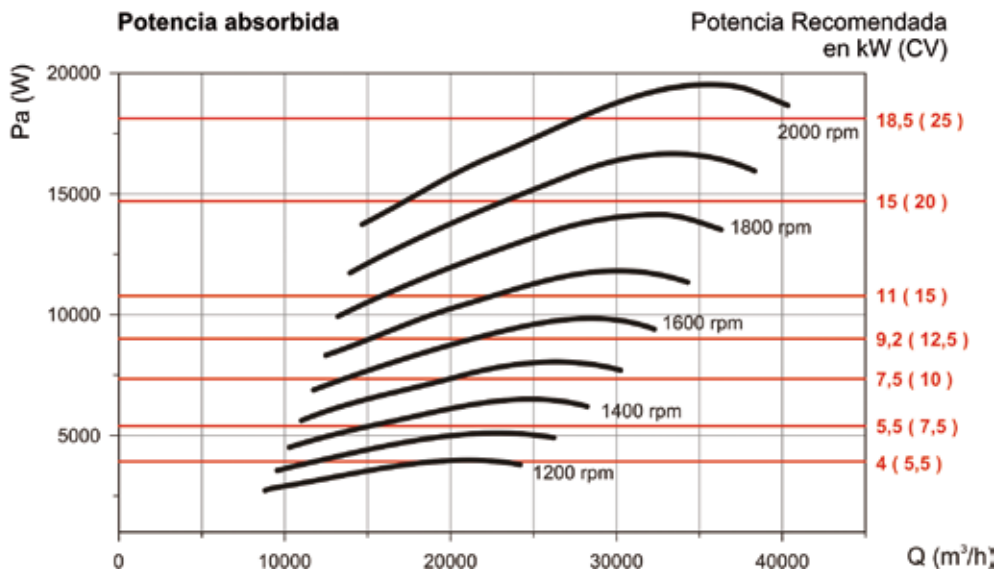
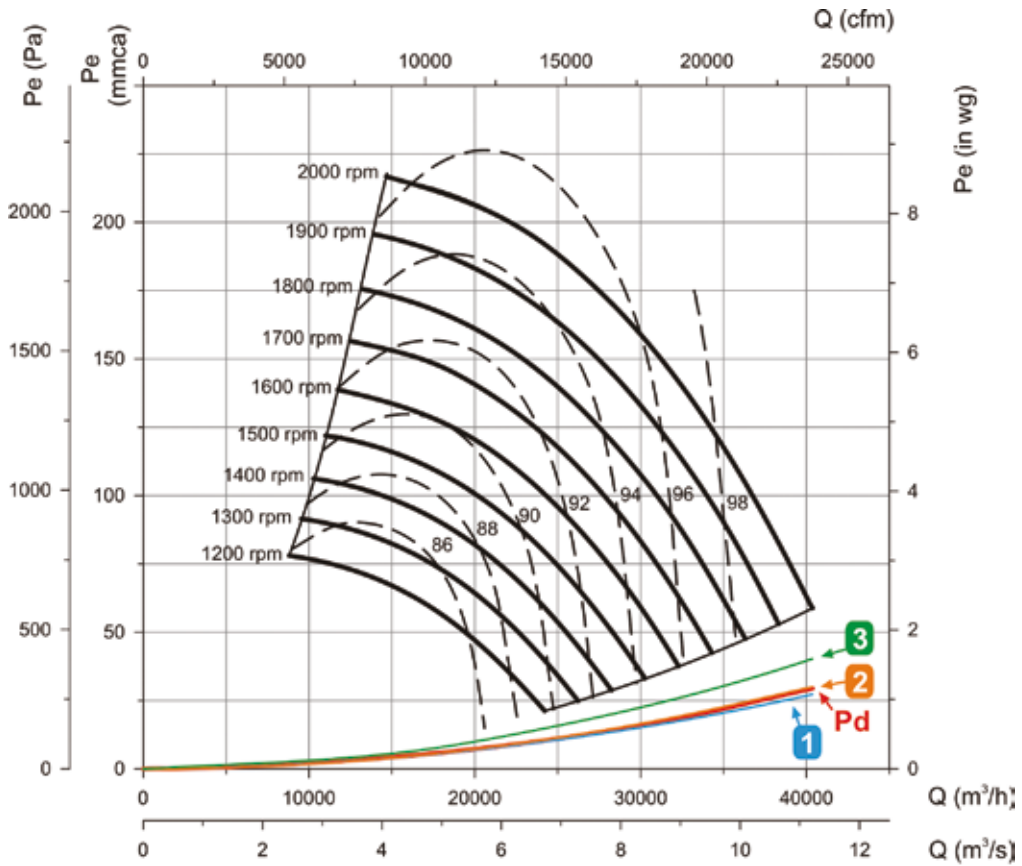

Translation of literals from the graph
 Potencia absorbida: Absorbed power
 Potencia Recomendada en kW (CV): Recommended Power in kW (CV)

Characteristic curves

Useful areas according to filters: **1** F6+F2 **2** F7+3 **3** F7+3 G4+F6
 Static pressure Dynamic pressure Sound power dB(A) - - -

UFRX-630

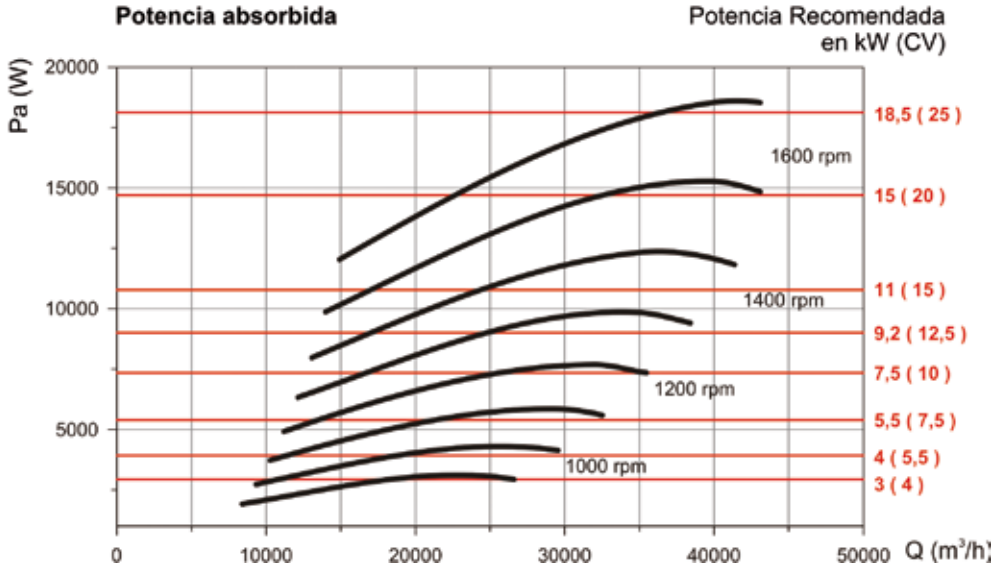
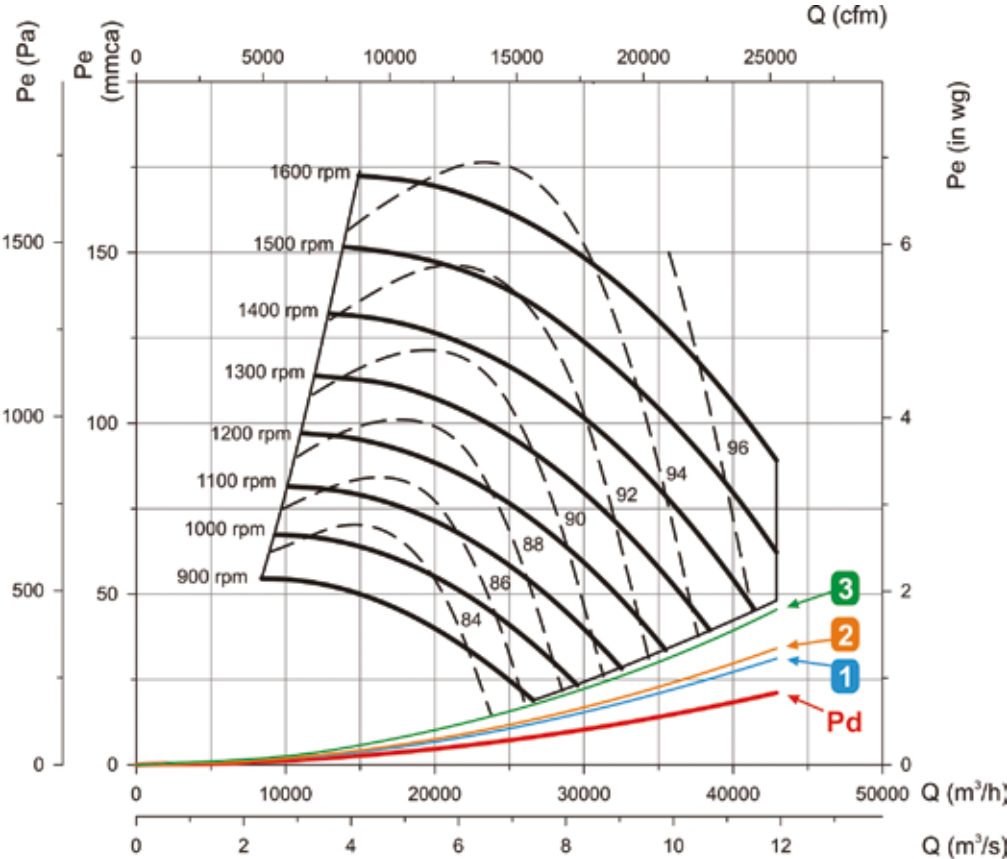

Translation of literals from the graph
 Potencia absorbida: Absorbed power
 Potencia Recomendada en kW (CV): Recommended Power in kW (CV)



UNI REMOTE CONTROL PANEL

External control designed for automatic operation of the energy recoverer, according to the variables entered. Applicable to models: RIS 260-1900 / RIRS 400-1500

Features:

- Adjustment and display of the entry temperature of air to the premises
- Adjustment and display of fan speed.
- Display of alarm signals
- RS-485 communications cable for remote control, length 13m



PRO REMOTE CONTROL PANEL

External control designed for automatic operation of the energy recoverer, according to the variables entered. Applicable to models: RIS 260-1900 / RIRS 400-1500

Features:

- Adjustment and display of the entry temperature of air to the premises
- Adjustment and display of fan speed.
- Control of the temperature of air entry, external temperature, temperature of the premises and temperature of the extracted air
- Display of alarm signals
- Timer with weekly programme (time of start-up, temperature of the premises, etc.)
- RS-485 communications cable for remote control, length 13m



BOX-E

Electronic for automatic control

External box, with the necessary electronics for the automatic control of the heat recuperators series RIS, RIS-P and RIRS. Applicable to the models which do not have it included as standard.



FILTERS

Air filters, for replacement in the filtration units and heat recuperators.



CJFILTER

Air filter boxes for circular ducts equipped with different types of filter, according to model.

- Envelope in galvanised sheet metal.
- Standard circular clamps in aspiration and impulsion, with airtight joints, to help in duct installation.
- Easy opening inspection and filter-change cover
- G-4, F-5, F-6, F7, F8 and F-9 filters, according to model

CJFILTER	100	F6
	diameter	Filters
	100 250	G4
	125 315	F5
	150 355	F6
	200 400	F7
		F8
		F9



ADIABATIC BOX

Box which incorporates an adiabatic module. It contributes to the cooling of the air supply to the premises. It is installed in the extraction circuit between the pre-filter and the exchanger.



SI-PRESOSTATO

Pressure sensor

Controls the pressure difference between filters, once it reaches the selected value it triggers a contact to activate an alarm relay.



SI-PRESIÓN

Pressure transmitter

Controls the pressure in installations with constant pressure ventilation, and transforms it into an electrical signal to regulate the ventilation system and constantly maintain the same pressure.

Model	Power	Outlet	Max. consumption (VA)	Ø Connectors	Pressure range
SI-PRESIÓN TPDA-3202	24V ac/24V dc	0-10V/4-20mA	4	6.2 mm	0-2500 Pa
SI-PRESIÓN TPDA-3202 c/DISPLAY	24V ac/24V dc	0-10V/4-20mA	4	6.2 mm	0-2500 Pa



CONSTANT FLOW KIT

A set made up of a pressure transmitter and frequency converter, designed to increase the speed of the fan as the filter gets dirtier, and to maintain a constant flow in the installation.



DIFFERENTIAL PRESSURE DRILL

Controls the difference in pressure between filters, to detect when the filters are dirty and need to be replaced.



WATER BATTERY FOR RECUP

Model	Applies to models
WB-200	RECUP-05
WB-250	RECUP-08
WB-315	RECUP-12 / RECUP-20 / RECUP-30
WB-500	RECUP-40 / RECUP-50 / RECUP-60



ELECTRICAL BATTERY FOR RECUP

Model	Applies to models	Power (kW)
EB-200-2-1	RECUP-05	2.0
EB-250-3-1	RECUP-08	3.0
EB-315-3-1	RECUP-12	3.0
EB-315-6-3	RECUP-20	6.0
EB-315-7.5-3	RECUP-30	7.5
EB-450-9-3	RECUP-40	9.0
EB-450-18-3	RECUP-50 / RECUP-60	18.0



INT

Stop-start safety switches in accordance with Standard UNE-EN 60204-1.

Features:

- Switches to install beside fan, so that mains current can be cut without handling the fan
- IP65 protection
- For three-phase or two-speed fans, use 6-pole switch
- Single-phase fans, use switch of 3 poles

Model	Current (A)	(kW)	Cable input (mm)
INT-CA 10/3CA	20	5.5	19
INT-KG 10/3CA	20	5.5	23
INT-KG 20/3CA	25	7.5	29
INT-KG 32/3CA	32	11	29
INT-KG 41/3CA	40	15	37.5
INT-KG 64/3CA	63	22	37.5
INT-KG 80/3CA	80	30	37.5
INT-KG 100/3CA	100	37	37.5
INT-CA 10/6CA	20	5.5	19
INT-KG 10/6CA	20	5.5	23
INT-KG 20/6CA	25	7.5	29
INT-KG 32/6CA	32	11	29
INT-KG 41/6CA	40	15	37.5
INT-KG 64/6CA	63	22	37.5
INT-KG 80/6CA	80	30	37.5
INT-KG 100/6CA	100	37	37.5



VIS

Outlet hoods and inlet with protective grille.

Prevents objects and water from entering the interior of the filtration units.



TEJ

Outside covers.

Avoids water entering filtration units installed outside.



BG

Base stand

Base for the support of the filtration units on the ground.



SB

Vibration dampers

Spring dampers to prevent the transmission of vibrations

OUR PRODUCTS

In-line duct fans



Ventilation systems for houses



Heat recovery units



Axial fans



Roof fans



Filtration units



Centrifugal fans



Efficient Energy Applications



Air curtains



ATEX Fans for explosive atmospheres



Fans for smoke extraction
400°C/2h - 300°C/1h



Ask us for information

Ventilation software.
General Catalogue





Crta. de Berga, km 0.7
E-08580 SANT QUIRZE DE BESORA
Barcelona - SPAIN
Tel. +34 93 852 91 11
Fax +34 93 852 90 42
comercial@sodeca.com
Export sales: ventilation@sodeca.com
www.sodeca.com



Export sales

SODECA EXPORT

Crta. de Berga, km 0.7
E-08580 SANT QUIRZE DE BESORA
Barcelona - SPAIN
Tel. +34 93 852 91 11
Fax +34 93 852 90 42
ventilation@sodeca.com

PORTUGAL

Mr. Albert Bartés
E-08580 SANT QUIRZE DE BESORA
Barcelona - SPAIN
Tel. +34 93 852 91 11
Fax +34 93 852 90 42
comercial@sodeca.com

SODECA SOUTH AMERICA

Sodeca Ventiladores Ltda
Avda. Puerta Sur 03380
San Bernardo, SANTIAGO, CHILE
ventilation@sodeca.com

SODECA CARIBBEAN AREA

Mr. Carlos A. Hernández Gil
Residencial Miramar N° 120B-7ma Ave.
NO. 1805 entre 18 y 20.
Miramar Playa, CIUDAD DE LA HABANA, CUBA
Tel. 00537 20 43721
sodeca@enet.cu



Ctra. de Berga, km 0,7
E-08580 SANT QUIRZE DE BESORA
(Barcelona - Spain)
Tel. +34 93 852 91 11
Fax +34 93 852 90 42
comercial@sodeca.com
Export sales: ventilation@sodeca.com

www.sodeca.com

